

I-2-5.71

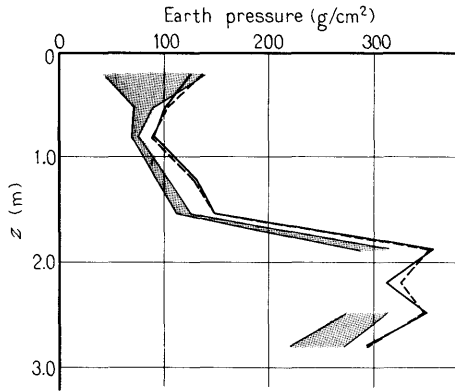

①

z m	p g/cm ²	γ deg
0.21	50.1	129
0.51	10.3	136
0.81	2.2	-155
1.21	5.9	-85
1.54	5.8	-75
1.89	13.3	-77
2.20	—	—

z m	p g/cm ²	γ deg
2.49	18.7	-72
2.80	28.3	-71
Bottom (No.6)	99.1	149
z m	D mm	λ deg
0	0.477	-165
2.16	0.263	-157
$f = 5.71$ Hz		

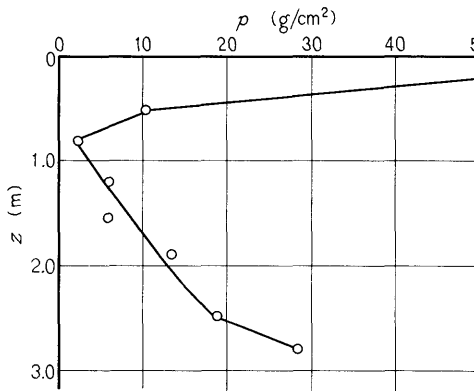

②

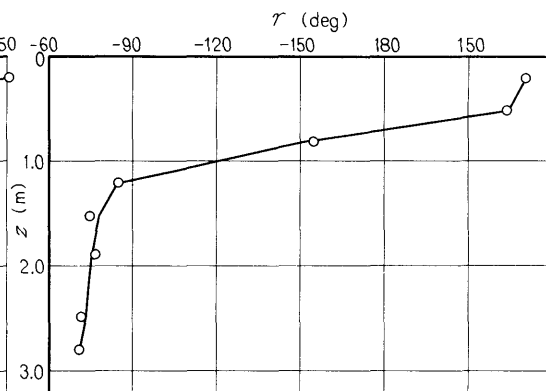

③

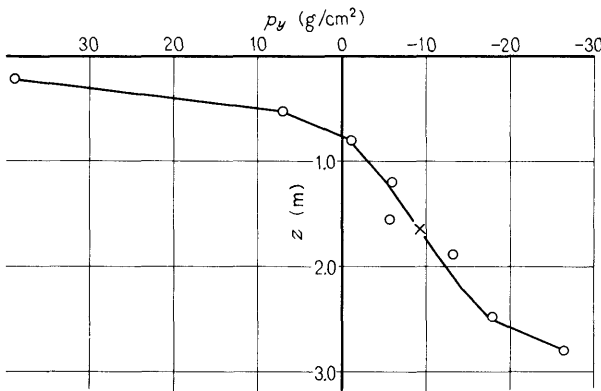

④

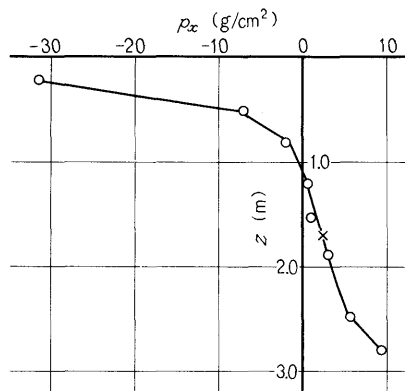

⑤

Fig. 39-(19)

I-2-5.87

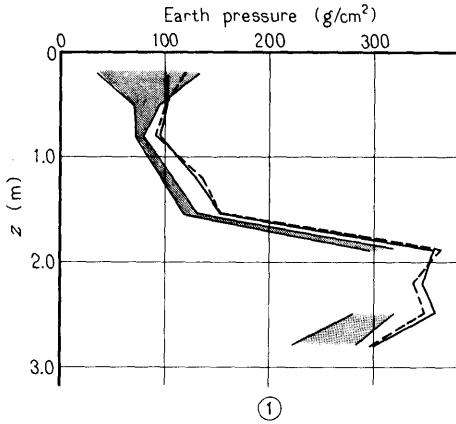

z m	p g/cm ²	γ deg	z m	p g/cm ²	γ deg
0.21	51.2	127	2.49	18.5	-72
0.51	12.3	134	2.80	28.9	-75
0.81	2.5	165	Bottom (No.6)	99.0	148
1.21	6.0	-92	z m	D mm	λ deg
1.54	6.5	-76	0	0.442	-177
1.89	13.1	-81	2.16	0.232	-167
2.20	—	—	$f = 5.87$ Hz		

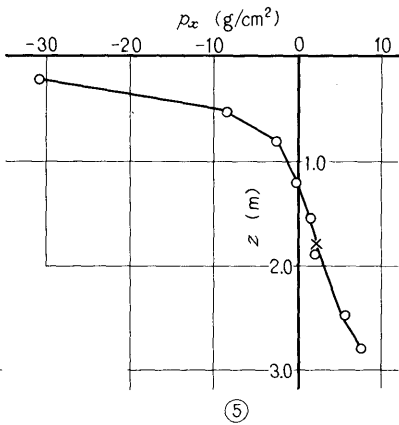
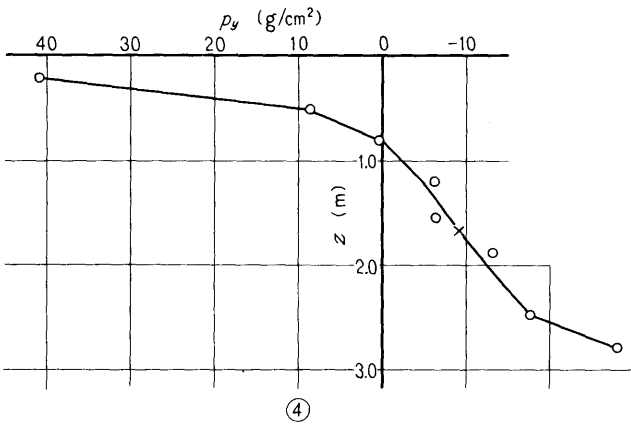
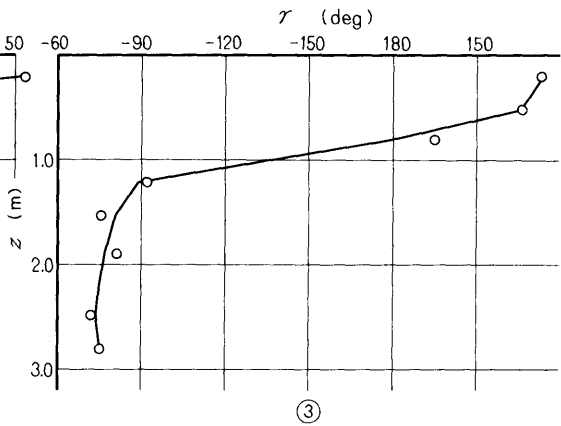
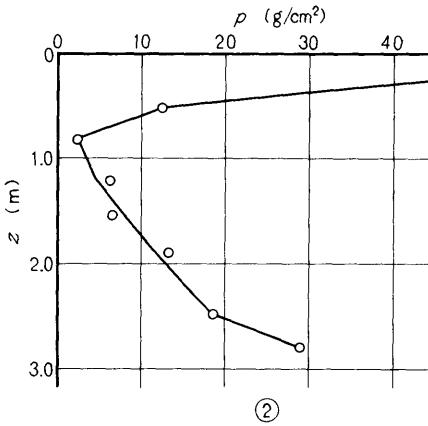
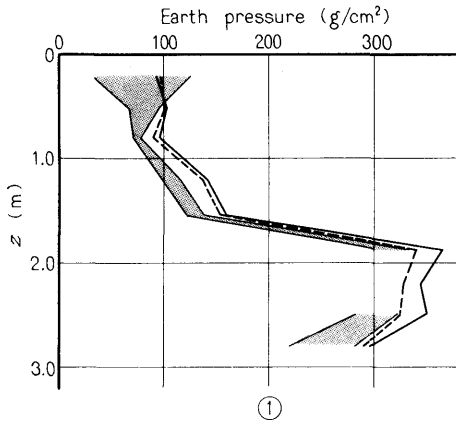

Fig. 39-(20)

I-2-5.93



z m	p g/cm^2	γ deg
0.21	50.6	125
0.51	15.6	135
0.81	3.5	172
1.21	6.6	-93
1.54	6.9	-82
1.89	14.6	-82
2.20	—	—

z m	p g/cm^2	γ deg
2.49	19.8	-77
2.80	30.0	-75
Bottom (No.6)	97.2	145
z m	D mm	λ deg
0	0.433	-174
2.16	0.221	-168
$f = 5.93$ Hz		

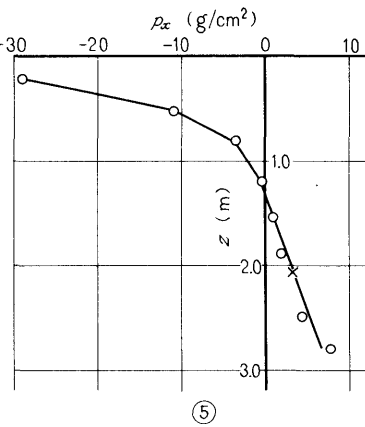
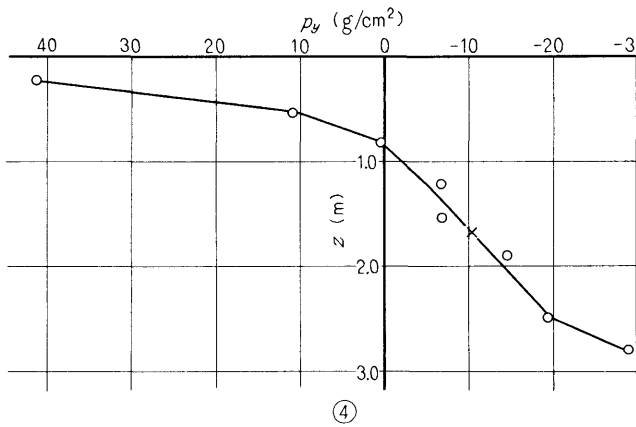
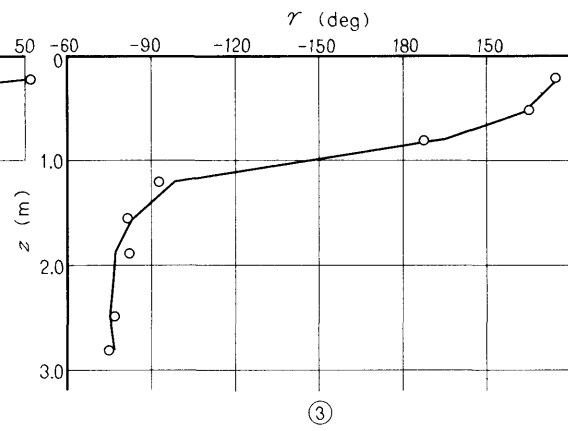
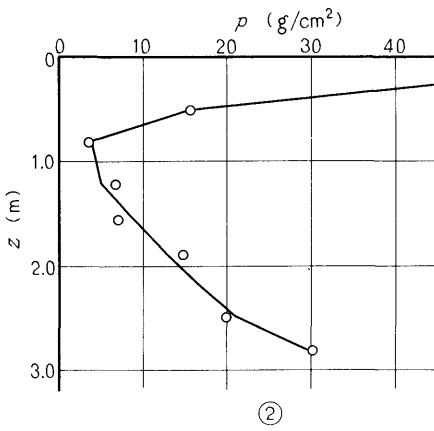
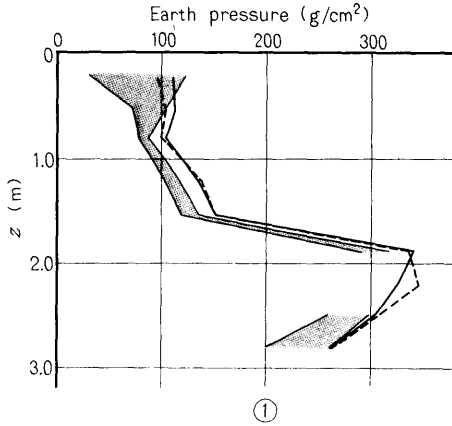

Fig. 39-(21)

I-2-5.94



z m	p g/cm^2	γ deg
0.21	55.2	127
0.51	17.7	130
0.81	3.4	164
1.21	6.7	-92
1.54	7.7	-74
1.89	13.5	-79
2.20	—	—

z m	p g/cm^2	γ deg
2.49	19.6	-79
2.80	30.3	-75
Bottom (No. 6)	105.8	144
z m	D mm	λ deg
0	0.441	-176
2.16	0.220	-168
$f = 5.94$ Hz		

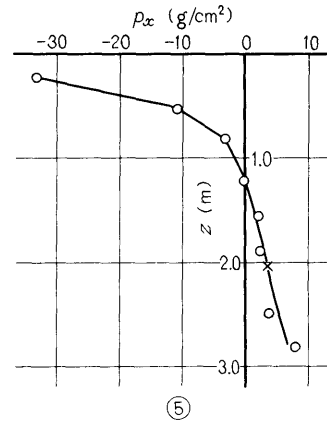
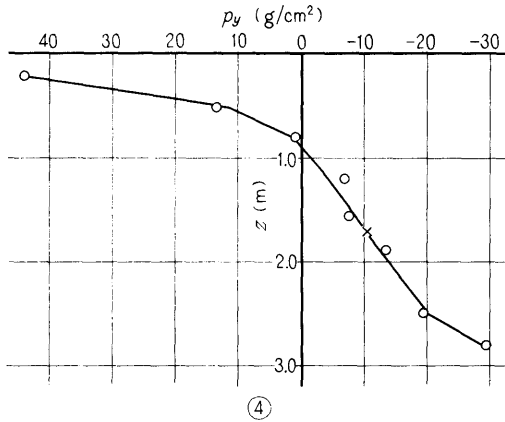
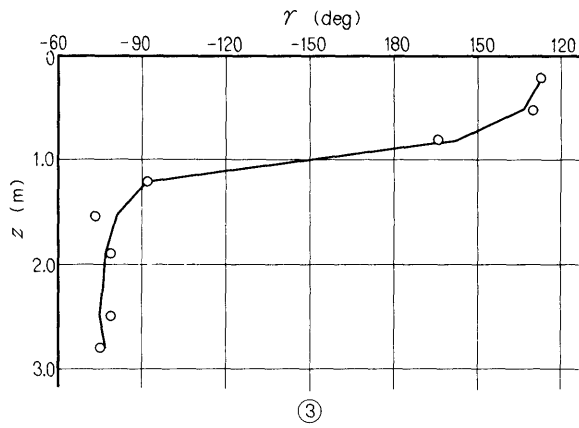
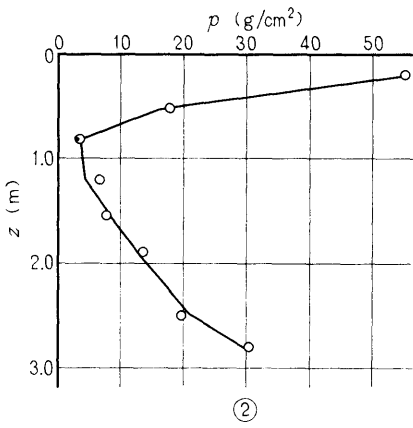
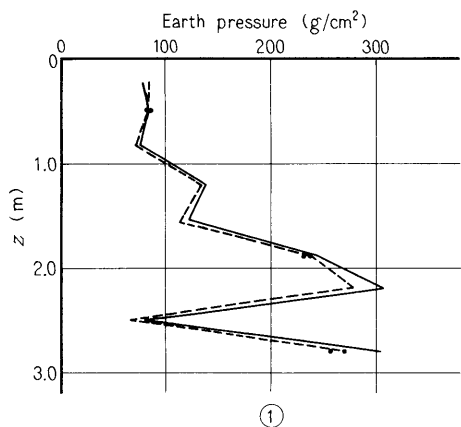

Fig. 39-(22)

I-3-3.29



z m	p g/cm ²	γ deg	z m	p g/cm ²	γ deg
0.21	—	—	2.49	—	—
0.51	0.7	-30	2.80	7.2	-19
0.81	—	—	Bottom (No.6)	—	—
1.21	—	—	z m	D mm	λ deg
1.54	—	—	0	0.0911	-3
1.89	2.2	-4	2.16	0.0650	-2
2.20	—	—	$f = 3.29$ Hz		

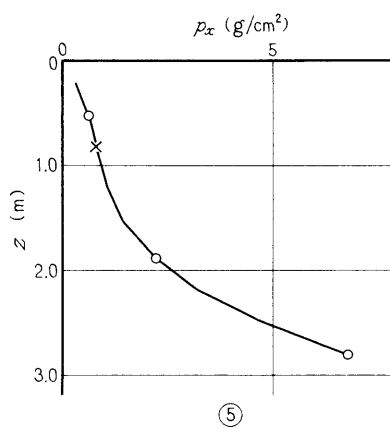
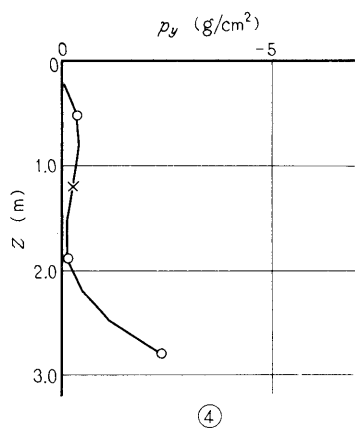
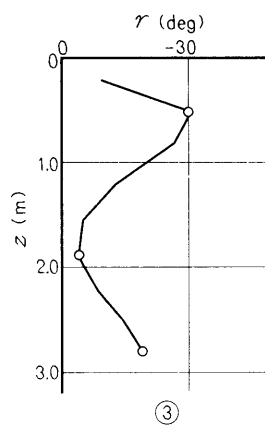
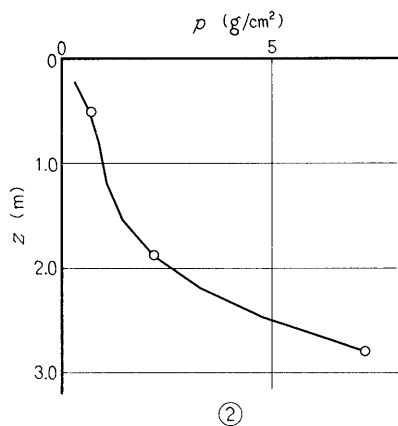
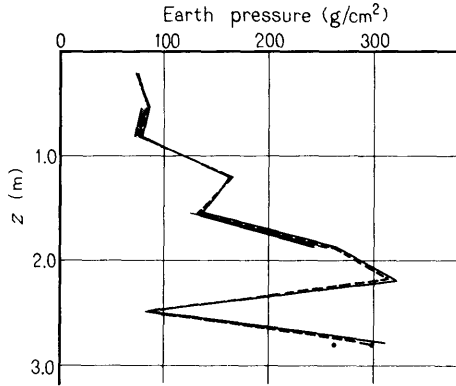

Fig. 39-(23)

I-3-4.30



①

z m	p g/cm ²	γ deg
0.21	—	—
0.51	2.6	-73
0.81	1.7	-64
1.21	—	—
1.54	3.1	-50
1.89	6.0	-48
2.20	—	—

z m	p g/cm ²	γ deg
2.49	—	—
2.80	15.4	-28
Bottom (No. 6)	24.6	-47
z m	D mm	λ deg
0	0.229	-51
2.16	0.178	-63
$f = 4.30$ Hz		

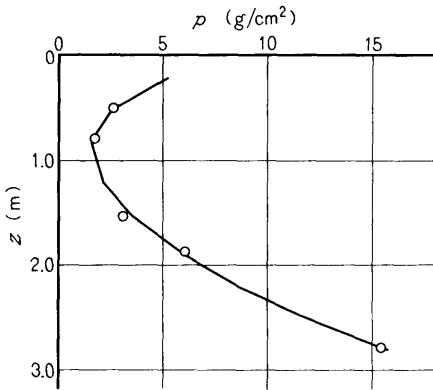

②

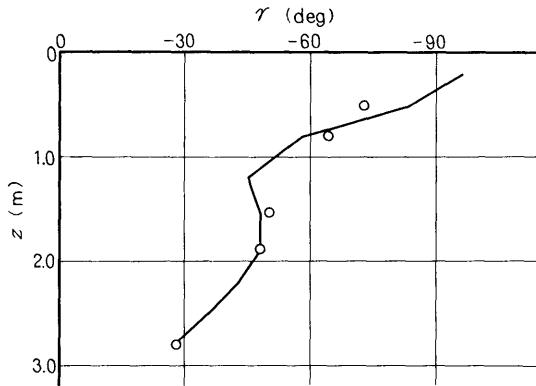

③

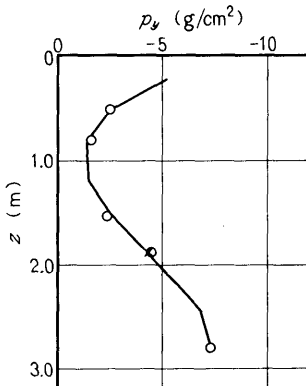

④

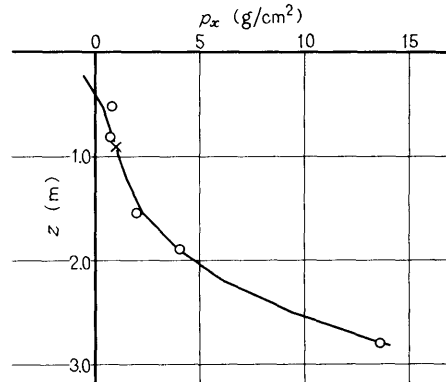

⑤

Fig. 39-(24)

I-3-4.35

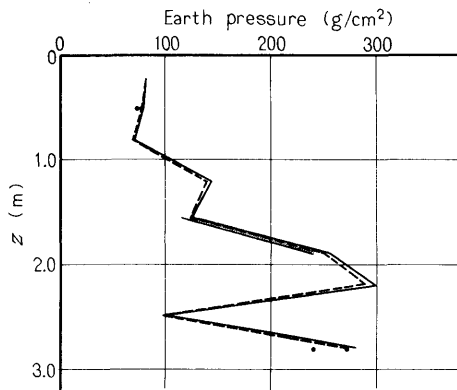

①

z m	p g/cm ²	γ deg
0.21	—	—
0.51	2.1	-69
0.81	—	—
1.21	—	—
1.54	3.8	-49
1.89	5.7	-48
2.20	—	—

z m	p g/cm ²	γ deg
2.49	—	—
2.80	14.9	-32
Bottom (No. 6)	28.2	-46
z m	D mm	λ deg
0	0.231	-55
2.16	0.170	-60
$f = 4.35$ Hz		

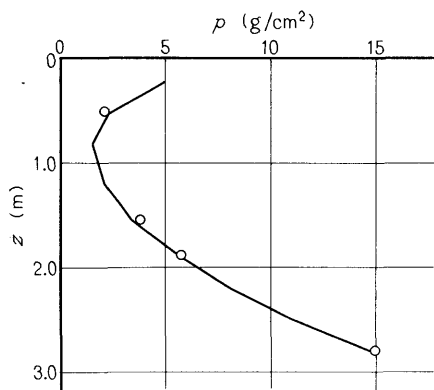

②

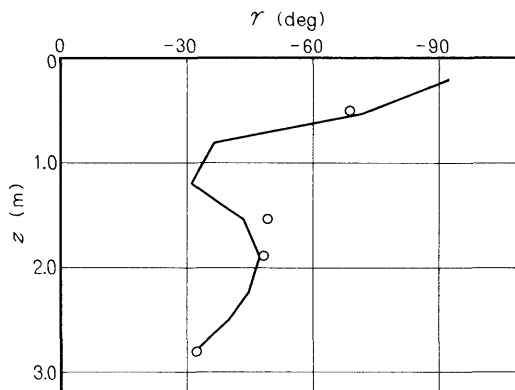

③

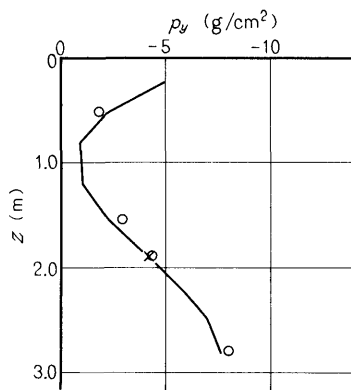

④

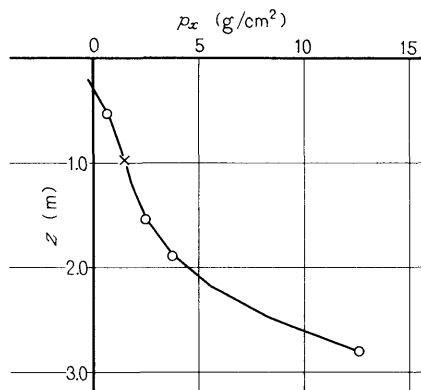

⑤

Fig. 39-(25)

I-3-5.07

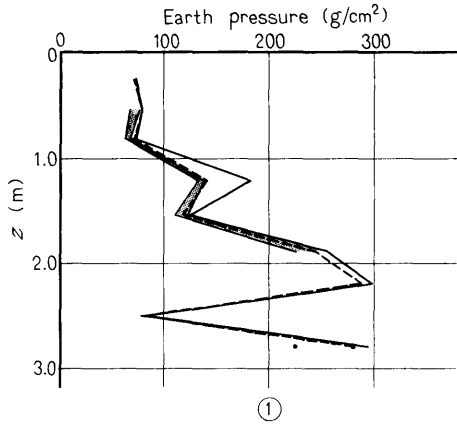

z m	p g/cm ²	γ deg	z m	p g/cm ²	γ deg
0.21	—	—	2.49	—	—
0.51	6.0	-92	2.80	26.9	-61
0.81	2.3	-99	Bottom (No. 6)	46.5	-95
1.21	2.6	-99	z m	D mm	λ deg
1.54	5.7	-77	0	0.397	-87
1.89	10.3	-75	2.16	0.286	-104
2.20	—	—	f = 5.07 Hz		

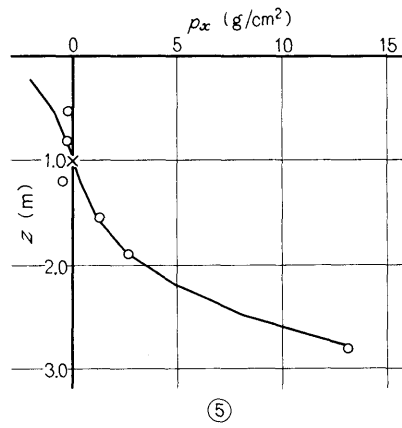
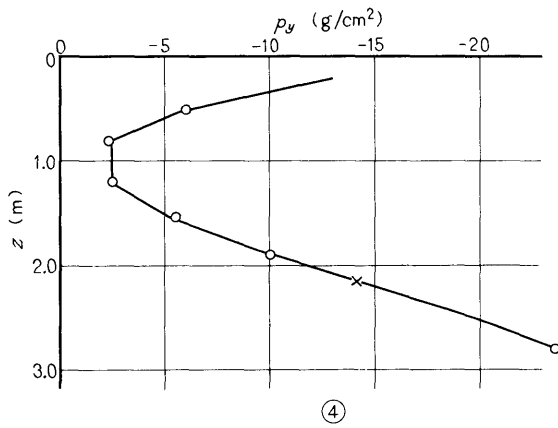
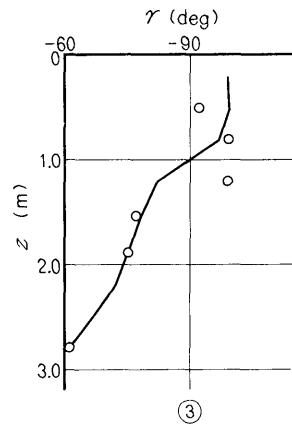
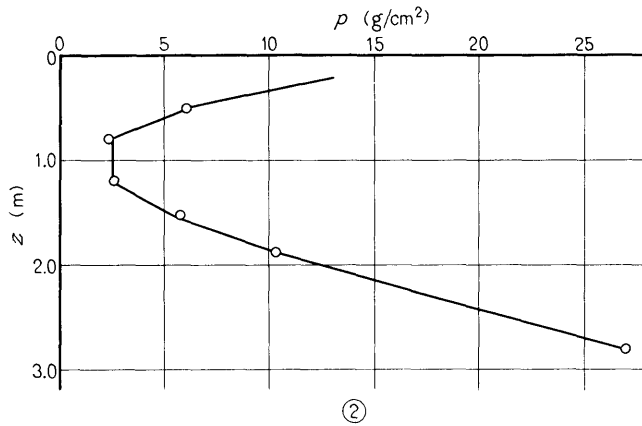
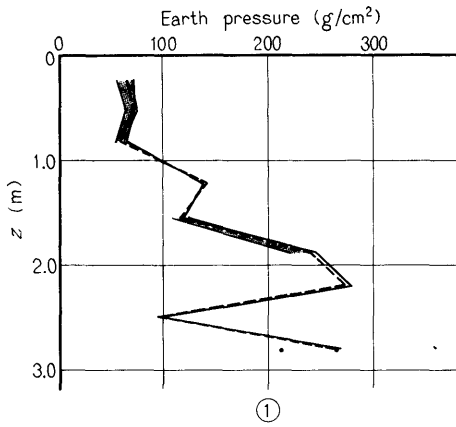

Fig. 39-(26)

I-3-5.10



z m	p g/cm ²	γ deg
0.21	5.9	-136
0.51	5.3	-106
0.81	3.0	-97
1.21	—	—
1.54	6.9	-81
1.89	10.7	-75
2.20	—	—

z m	p g/cm ²	γ deg
2.49	—	—
2.80	27.0	-64
Bottom (No. 6)	47.7	-87
z m	D mm	λ deg
0	0.419	-83
2.16	0.298	-98
$f = 5.10$ Hz		

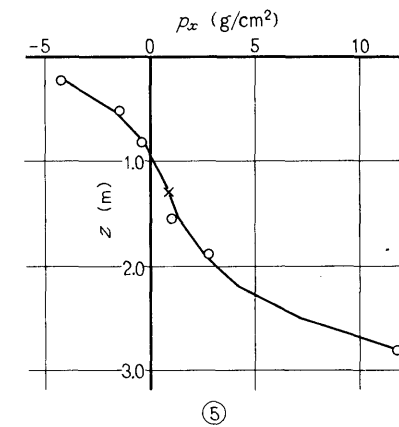
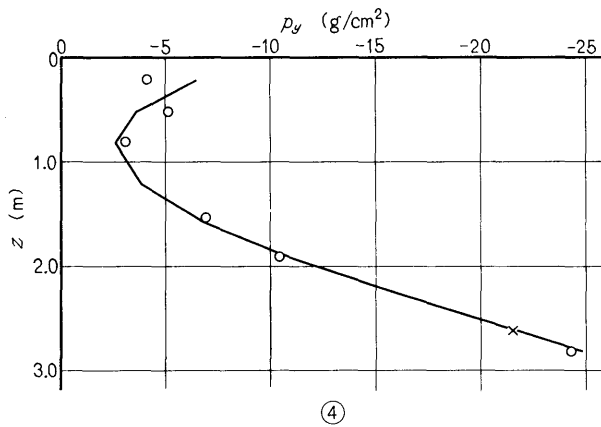
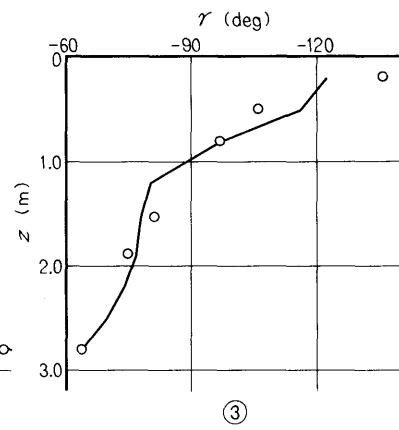
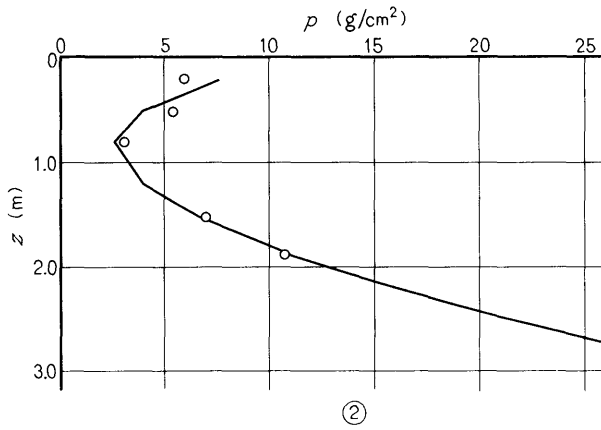
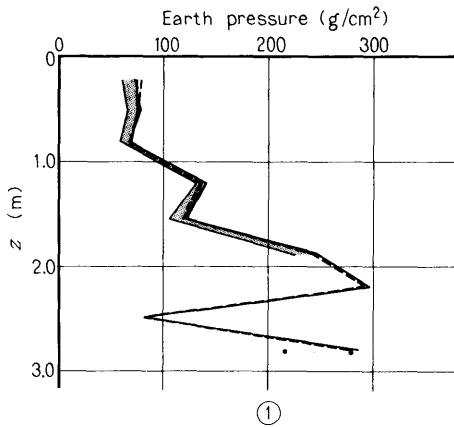

Fig. 39-(27)

I-3-5.50



z m	p g/cm ²	γ deg	z m	p g/cm ²	γ deg
0.21	6.5	-126	2.49	—	—
0.51	6.0	-104	2.80	31.1	-75
0.81	4.1	-96	Bottom (No. 6)	60.2	-100
1.21	4.7	-93	z m	D mm	λ deg
1.54	8.5	-88	0	0.429	-90
1.89	10.7	-89	2.16	0.277	-111
2.20	—	—	$f = 5.50$ Hz		

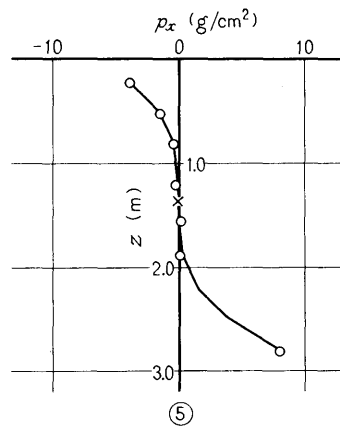
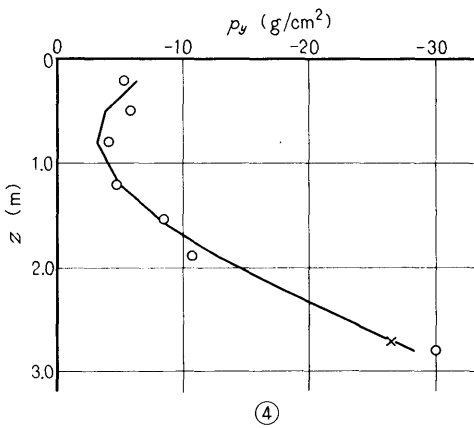
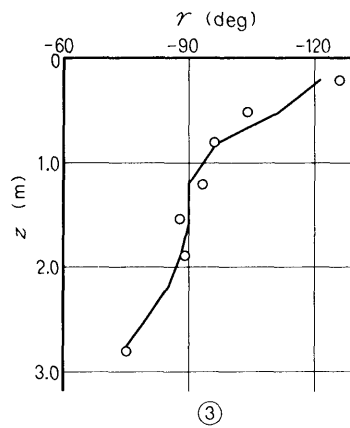
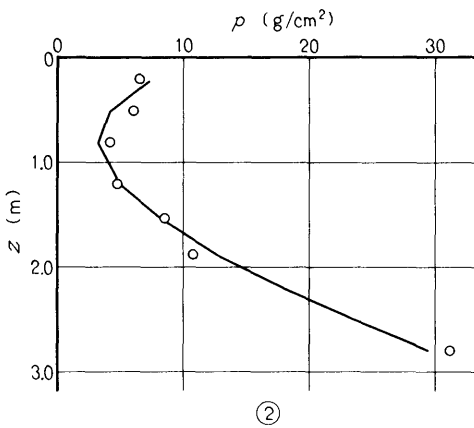
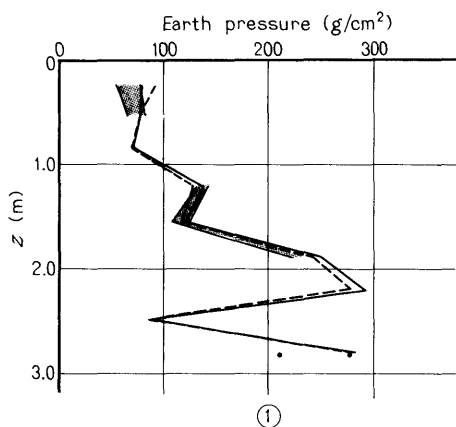

Fig. 39-(28)

I-3-5.77



z m	p g/cm ²	γ deg
0.21	13.0	-140
0.51	7.6	-120
0.81	—	—
1.21	5.7	-109
1.54	8.2	-101
1.89	13.6	-104
2.20	—	—

z m	p g/cm ²	γ deg
2.49	—	—
2.80	35.5	-101
Bottom (No.6)	61.5	-114
z m	D mm	λ deg
0	0.462	-108
2.16	0.288	-127
$f = 5.77$ Hz		

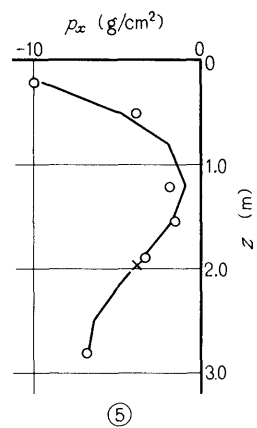
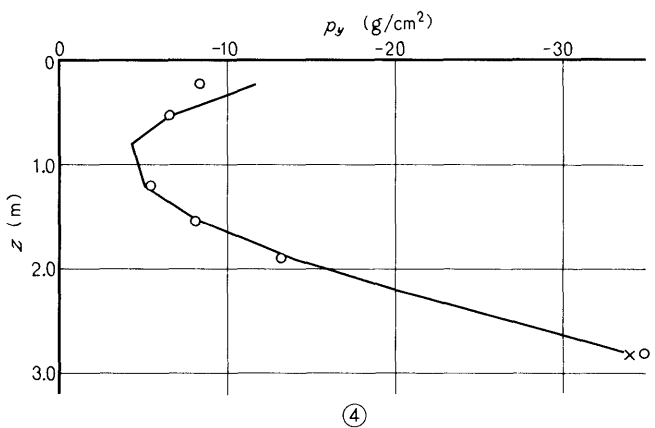
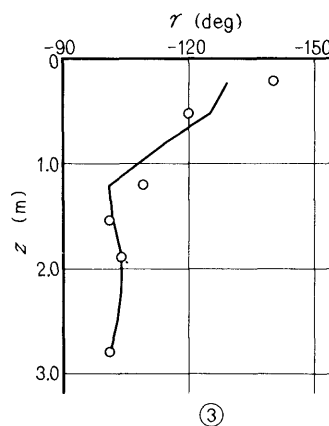
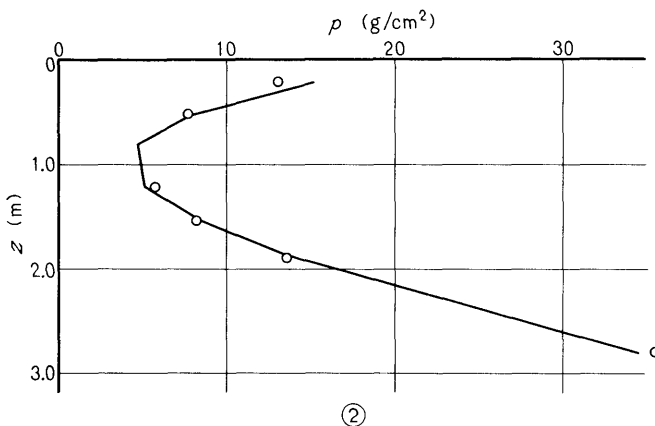
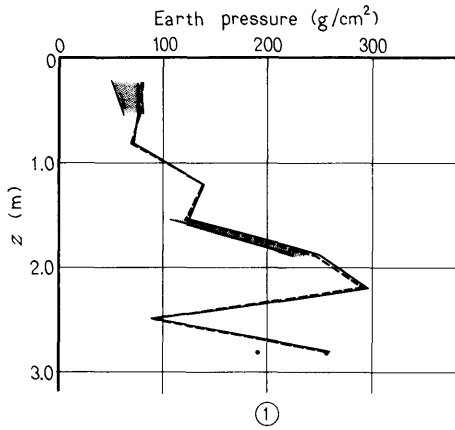

Fig. 39-(29)

I-3-5.90



z m	p g/cm ²	γ deg
0.21	13.2	-140
0.51	8.2	-128
0.81	—	—
1.21	—	—
1.54	8.6	-109
1.89	13.7	-109
2.20	—	—

z m	p g/cm ²	γ deg
2.49	—	—
2.80	33.8	-103
Bottom (No. 6)	67.1	-118
z m	D mm	λ deg
0	0.497	-107
2.16	0.296	-128
$f = 5.90$ Hz		

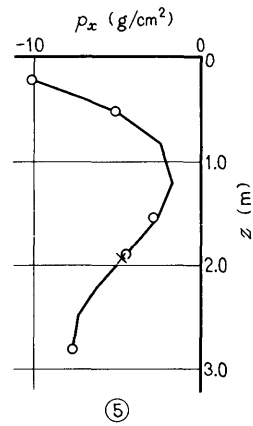
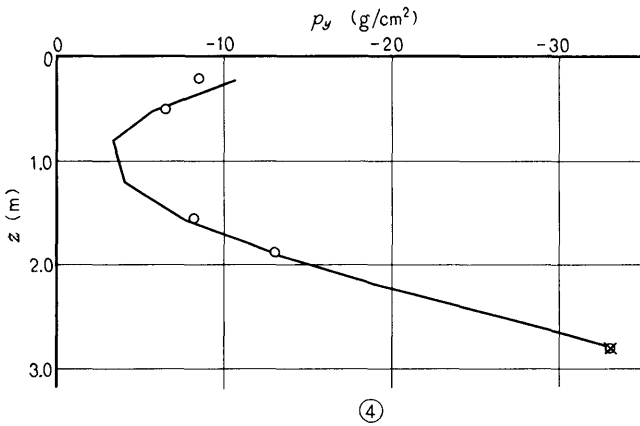
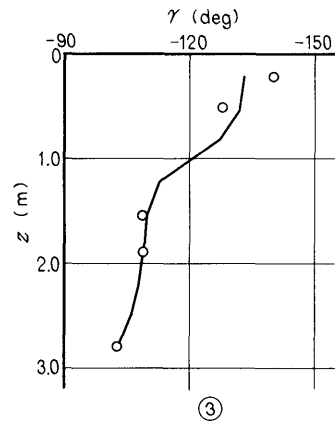
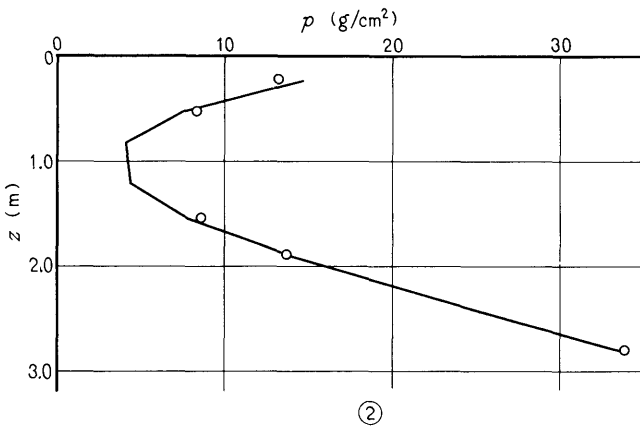

Fig. 39-(30)

I-3-5.95

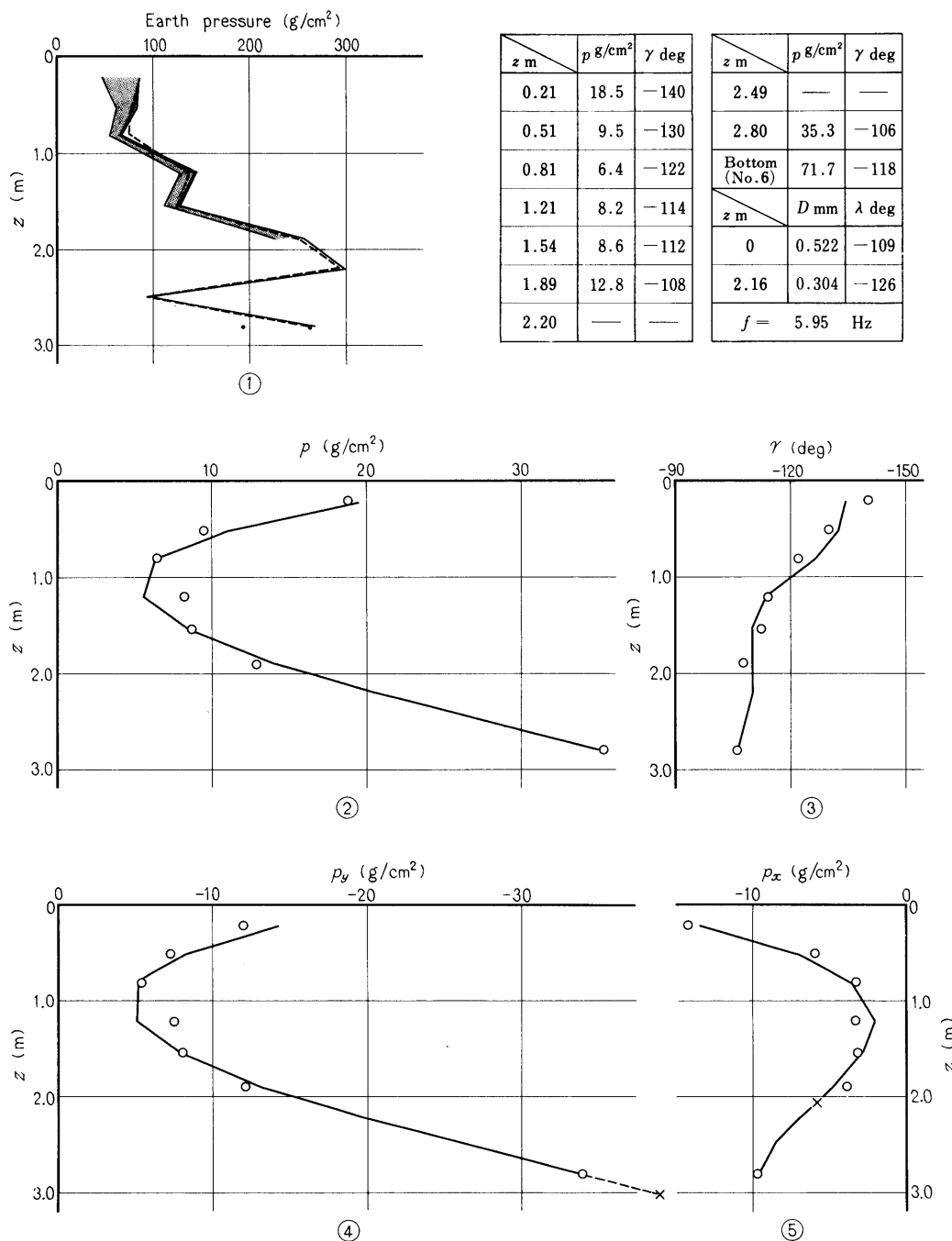
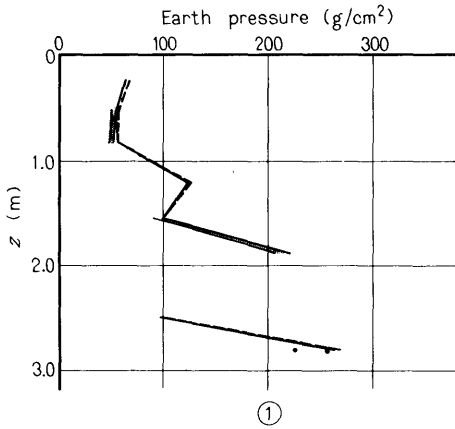

Fig. 39-(31)

I-4-4.43



z m	p g/cm ²	γ deg	z m	p g/cm ²	γ deg
0.21	—	—	2.49	—	—
0.51	1.9	-49	2.80	16.8	-31
0.81	1.5	-55	Bottom (No.6)	21.4	-47
1.21	—	—	z m	D mm	λ deg
1.54	4.1	-52	0	0.276	-44
1.89	6.0	-47	2.16	0.195	-56
2.20	—	—	$f = 4.43 \text{ Hz}$		

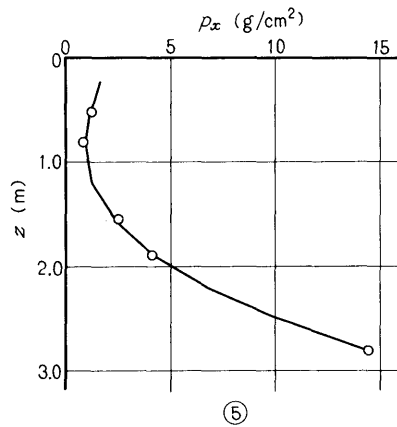
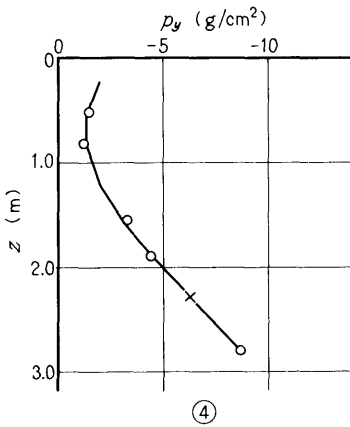
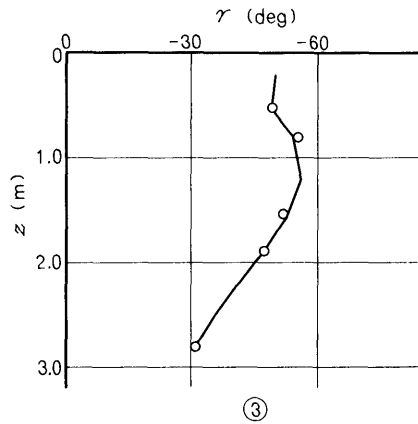
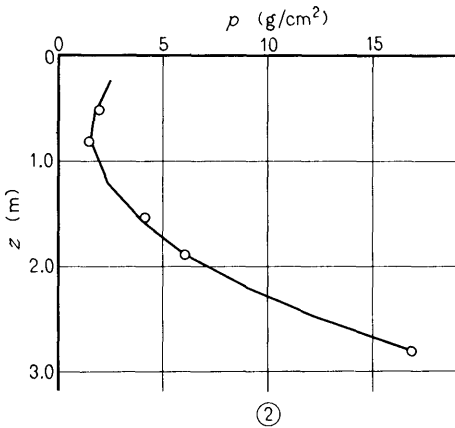
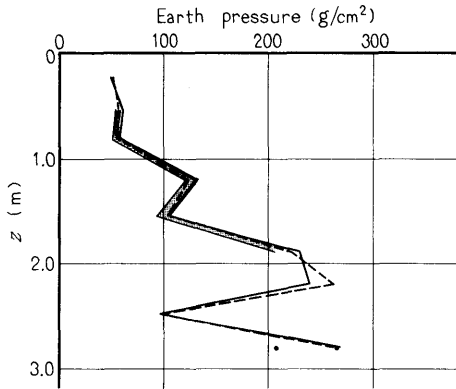

Fig. 39-(32)

I-4-5.08



①

z m	p g/cm ²	γ deg
0.21	—	—
0.51	2.2	-73
0.81	2.2	-99
1.21	6.1	-92
1.54	5.9	-79
1.89	11.2	-72
2.20	—	—

z m	p g/cm ²	γ deg
2.49	—	—
2.80	30.1	-56
Bottom (No.6)	47.1	-83
z m	D mm	λ deg
0	0.435	-79
2.16	0.189	-96
$f = 5.08$ Hz		

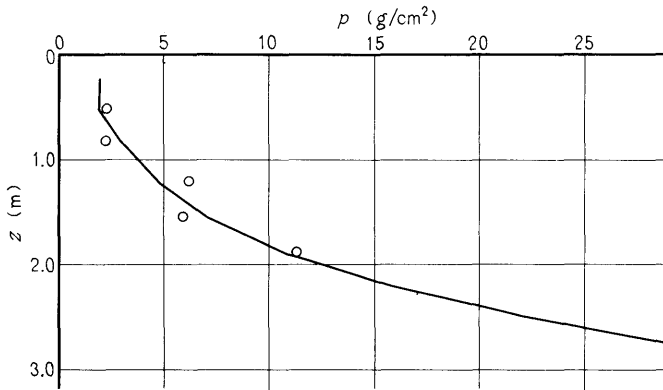

②

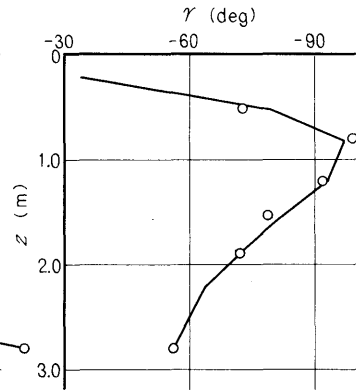

③

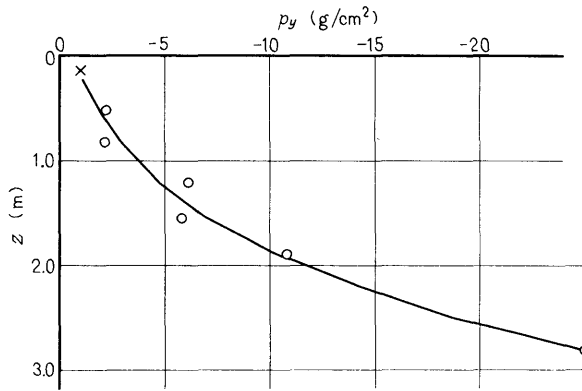

④

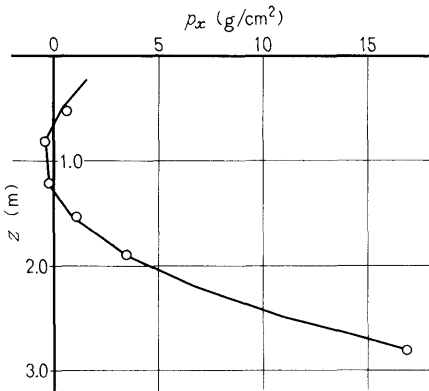

⑤

Fig. 39-(33)

I-4-5.98

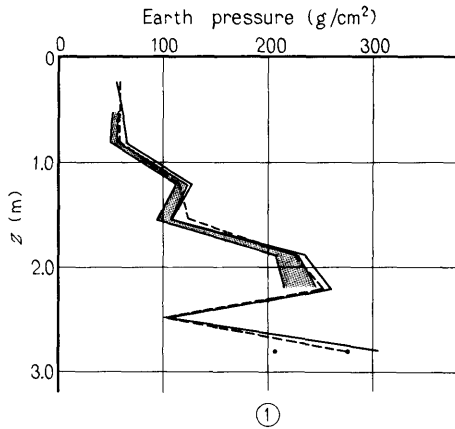

z m	p g/cm^2	γ deg
0.21	—	—
0.51	2.5	-105
0.81	2.9	-120
1.21	6.2	-105
1.54	8.0	-99
1.89	12.6	-104
2.20	14.6	-85

z m	p g/cm^2	γ deg
2.49	—	—
2.80	34.6	-97
Bottom (No.6)	61.1	-122
z m	D mm	λ deg
0	0.487	-116
2.16	0.287	-127
$f = 5.98$ Hz		

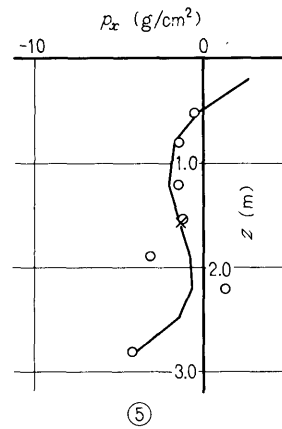
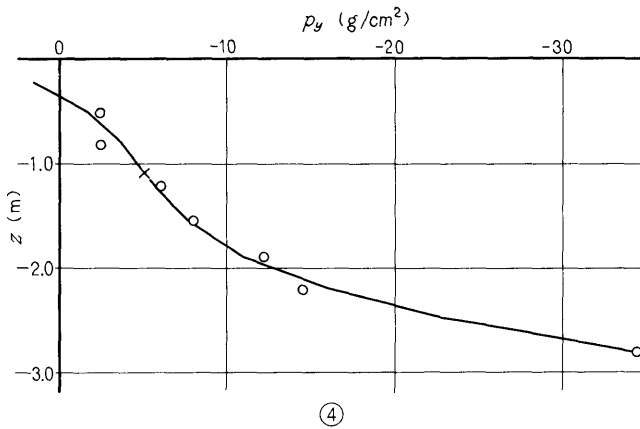
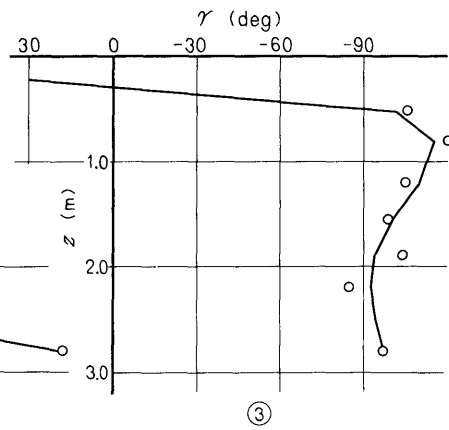
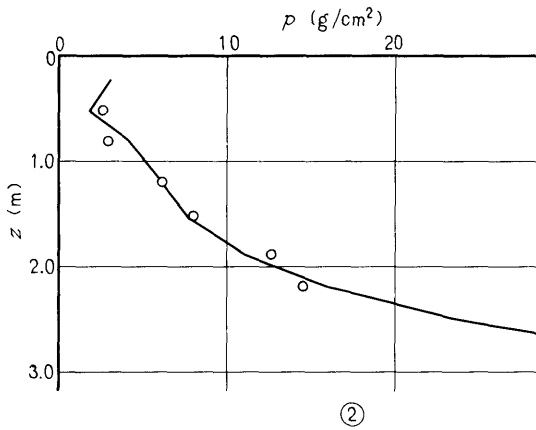
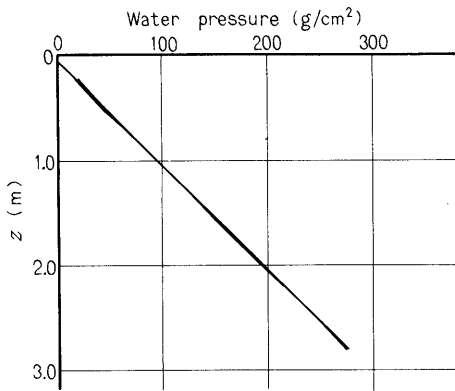

Fig. 39-(34)

I-5-4.03



①

z m	p g/cm ²	γ deg	z m	p g/cm ²	γ deg
0.21	0.4	-132	2.49	—	—
0.51	0.5	-120	2.80	—	—
0.81	—	—	Bottom (No.6)	14.4	-80
1.21	—	—	z m	D mm	λ deg
1.54	0.6	-105	0	0.213	-73
1.89	0.5	-120	2.16	0.129	-65
2.20	—	—	$f = 4.03$ Hz		

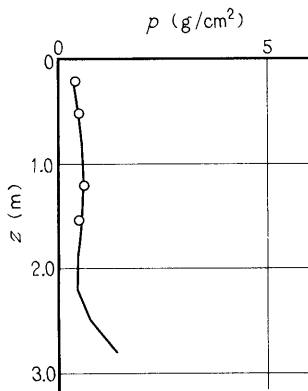

②

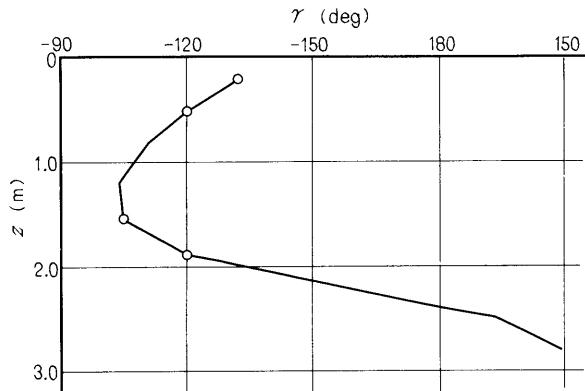

③

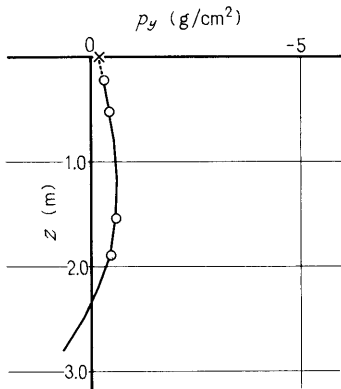

④

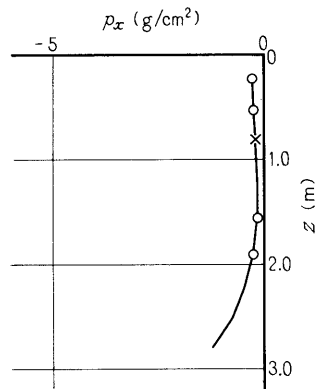

⑤

Fig. 39-(35) Vertical distributions of water pressures
 ○ : Observed values — : Empirical formula

I-5-4.88

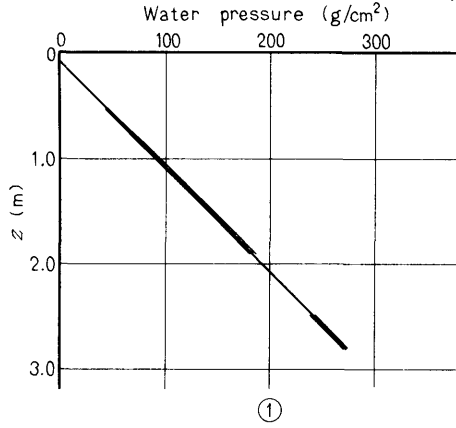

z m	p g/cm^2	γ deg	z m	p g/cm^2	γ deg
0.21	—	—	2.49	1.9	-158
0.51	1.4	-161	2.80	2.2	179
0.81	1.0	-168	Bottom (No.6)	21.4	-137
1.21	2.1	-161	z m	D mm	λ deg
1.54	2.4	-161	0	0.384	-117
1.89	2.3	-165	2.16	0.246	-103
2.20	—	—	$f = 4.88$ Hz		

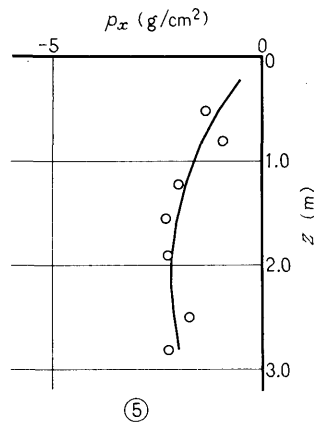
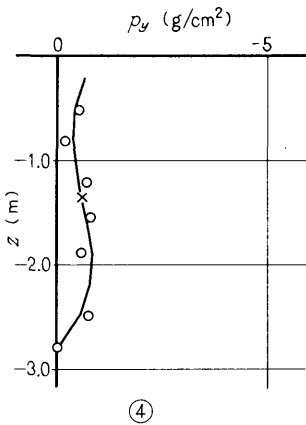
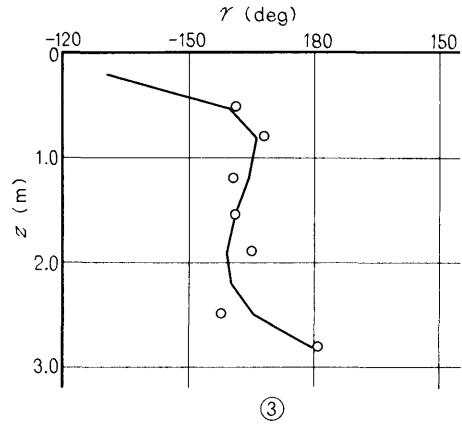
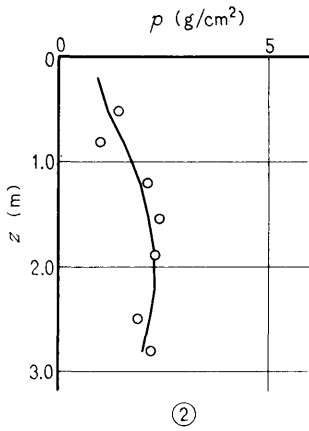
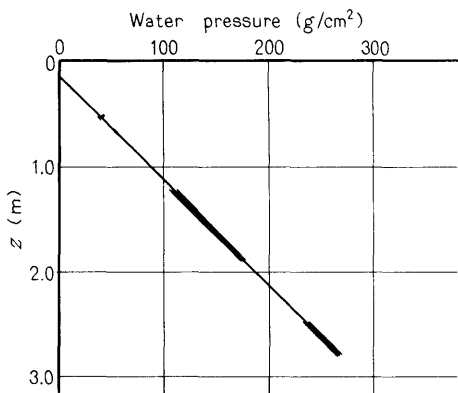

Fig. 39-(36)

I-5-5.40



①

z m	p g/cm ²	γ deg	z m	p g/cm ²	γ deg
0.21	—	—	2.49	2.4	153
0.51	1.3	159	2.80	2.1	174
0.81	—	—	Bottom (No.6)	25.8	175
1.21	3.0	162	z m	D mm	λ deg
1.54	2.6	155	0	0.421	-164
1.89	2.7	153	2.16	0.236	-147
2.20	—	—	$f = 5.40$ Hz		

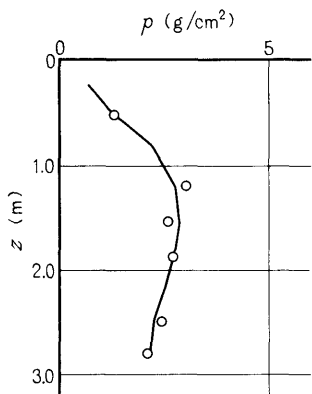

②

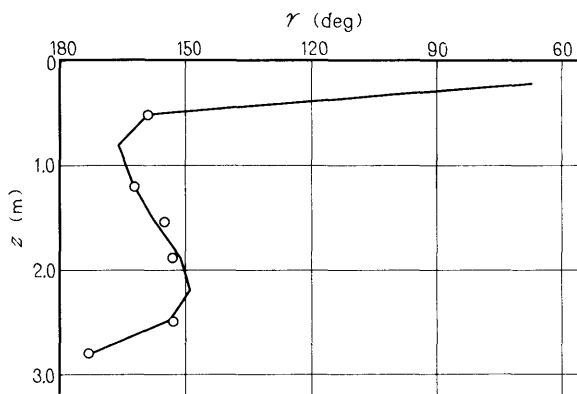

③

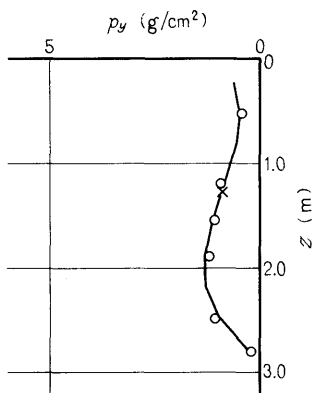

④

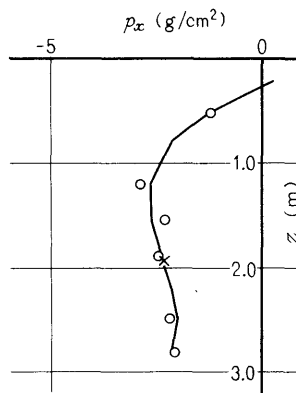

⑤

Fig. 39-(37)

I-5-5.72

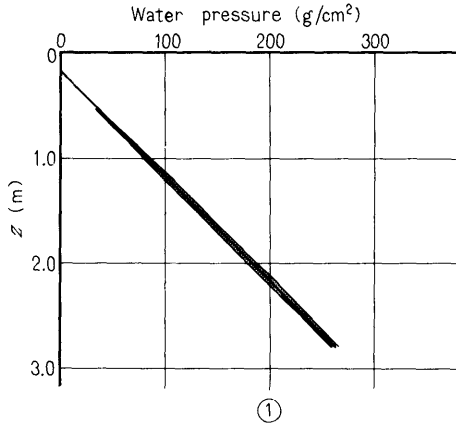

z m	p g/cm^2	γ deg	z m	p g/cm^2	γ deg
0.21	—	—	2.49	2.5	120
0.51	2.0	116	2.80	3.5	103
0.81	1.5	121	Bottom (No. 6)	28.9	142
1.21	4.1	114	z m	D mm	λ deg
1.54	3.7	109	0	0.513	148
1.89	3.7	107	2.16	0.257	159
2.20	5.4	98	$f = 5.72$ Hz		

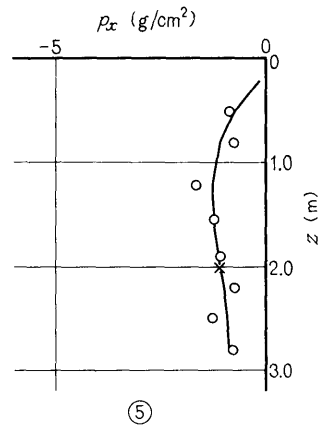
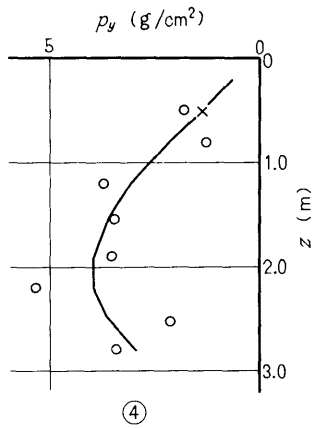
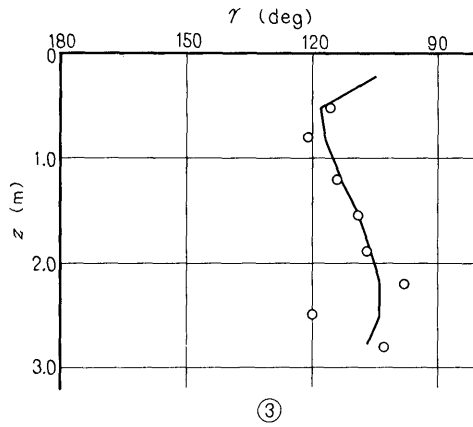
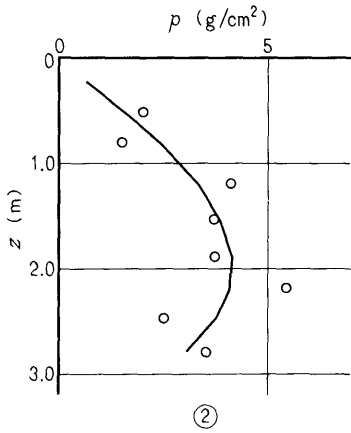
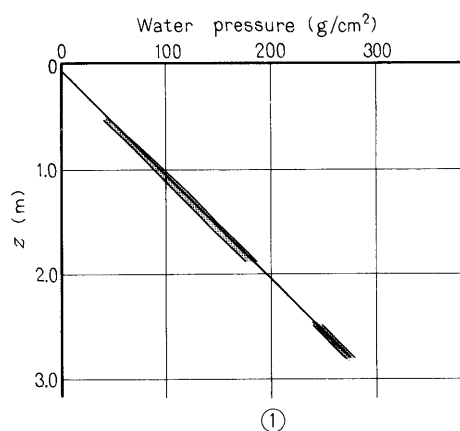

Fig. 39-(38)

I-5-5.85



z m	p g/cm^2	γ deg
0.21	—	—
0.51	2.5	59
0.81	2.5	58
1.21	4.8	54
1.54	5.1	65
1.89	5.0	55
2.20	—	—

z m	p g/cm^2	γ deg
2.49	3.3	56
2.80	4.8	68
Bottom (No. 6)		
z m	D mm	λ deg
0	0.553	91
2.16	0.173	111
$f = 5.85$ Hz		

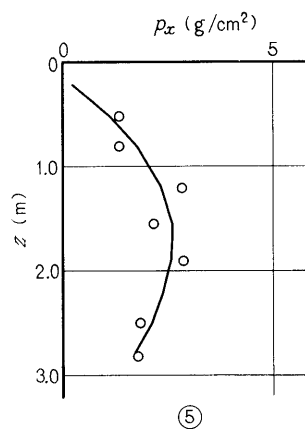
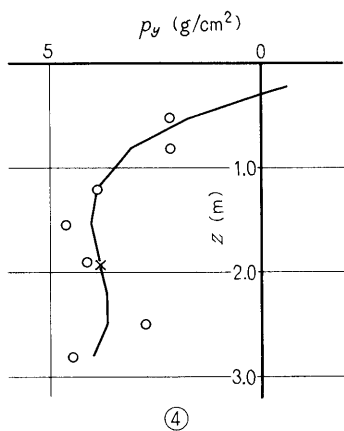
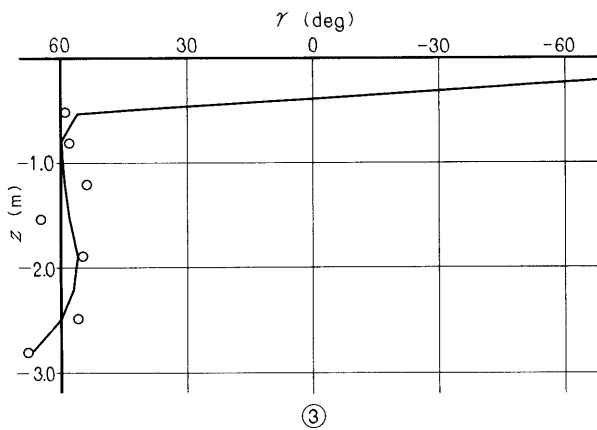
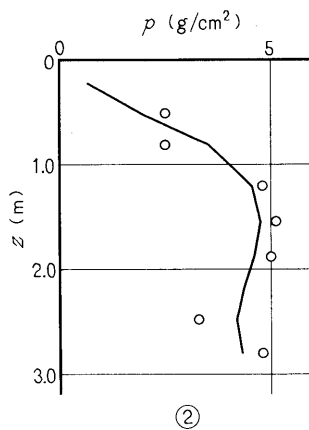
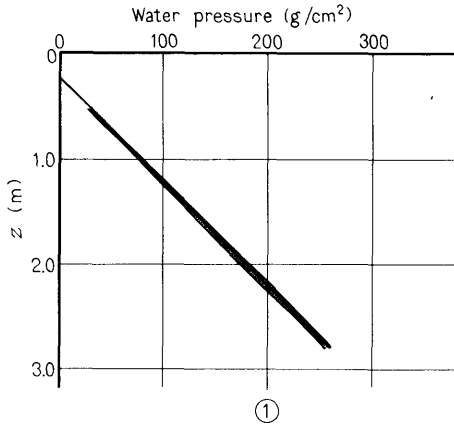

Fig. 39-(39)

I-5-5.93



z m	p g/cm ²	γ deg
0.21	—	—
0.51	1.9	121
0.81	1.9	107
1.21	3.6	113
1.54	3.4	117
1.89	3.7	109
2.20	5.2	111

z m	p g/cm ²	γ deg
2.49	3.8	109
2.80	4.2	99
Bottom (No.6)	31.2	138
z m	D mm	λ deg
0	0.565	150
2.16	0.270	163
$f = 5.93$ Hz		

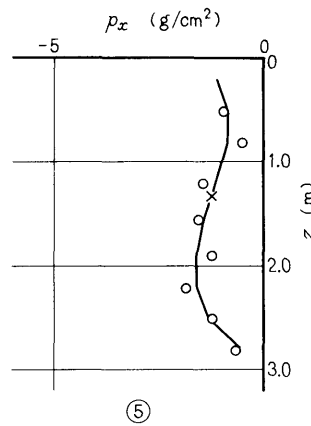
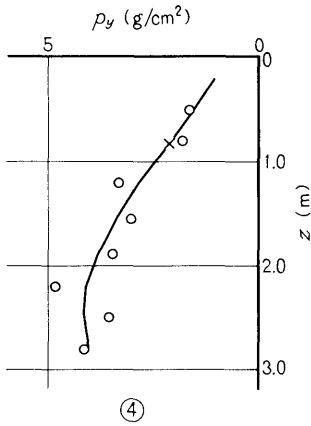
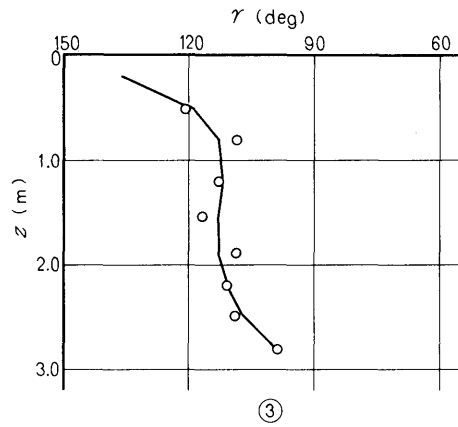
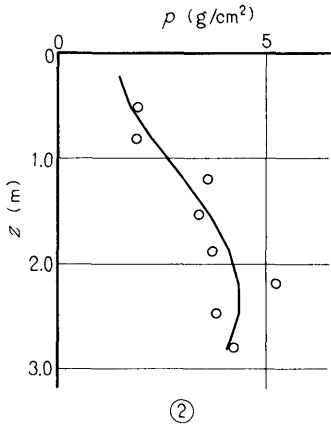
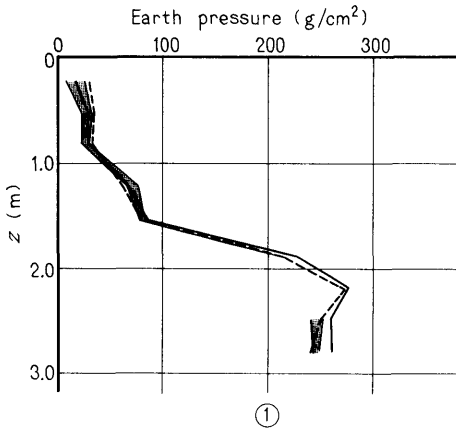

Fig. 39-(40)

II-1-5.53



z m	p g/cm ²	γ deg
0.21	8.5	-176
0.51	4.7	175
0.81	3.0	174
1.21	4.5	177
1.54	3.0	-177
1.89	4.2	-179
2.20	—	—

z m	p g/cm ²	γ deg
2.49	5.7	-173
2.80	3.0	12
Bottom (No.6)	23.4	4
z m	D mm	λ deg
0	0.0946	10
2.16	0.0276	0
$f = 5.53$ Hz		

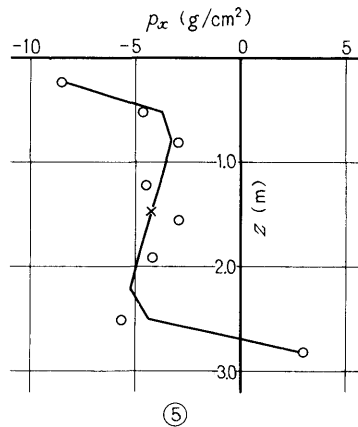
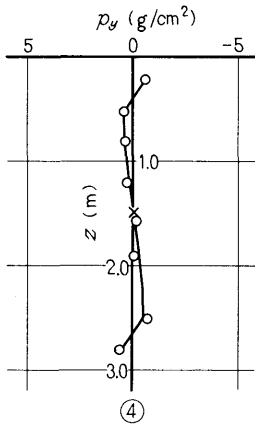
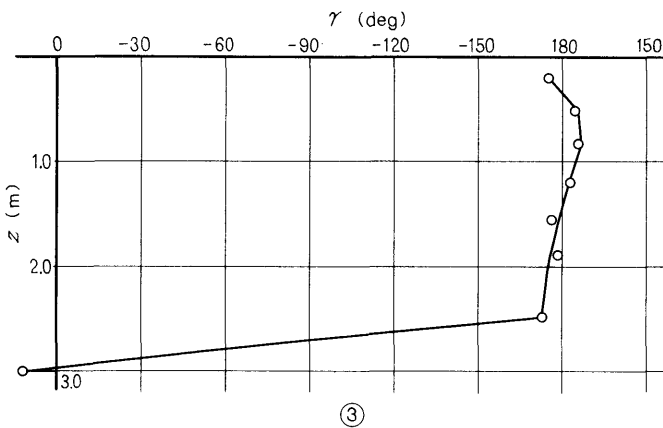
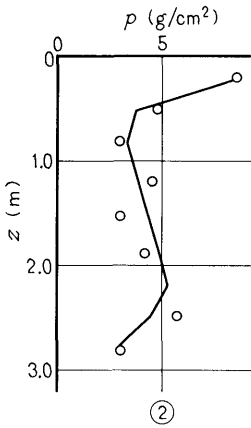
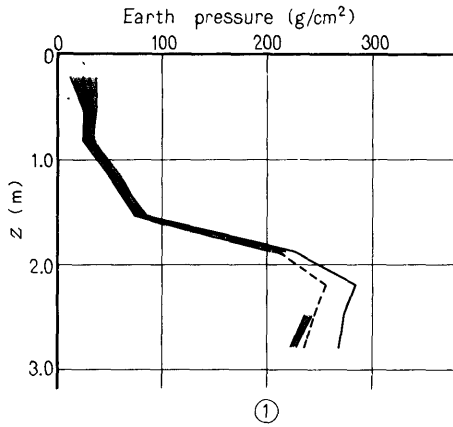

Fig. 39-(41) Vertical distributions of earth pressures
 ○ : Observed values — : Empirical formula

II-1-6.83



z m	p g/cm ²	γ deg	z m	p g/cm ²	γ deg
0.21	12.5	175	2.49	4.0	-169
0.51	6.1	172	2.80	2.0	-7
0.81	3.8	179	Bottom (No.6)	—	—
1.21	5.3	-174	z m	D mm	λ deg
1.54	3.9	-165	0	0.173	-4
1.89	5.2	-177	2.16	0.0557	-20
2.20	—	—	$f = 6.83$ Hz		

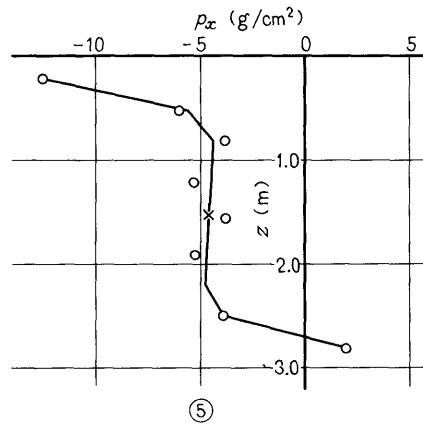
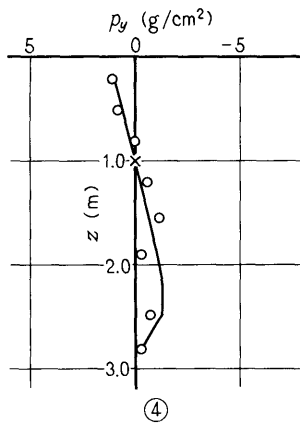
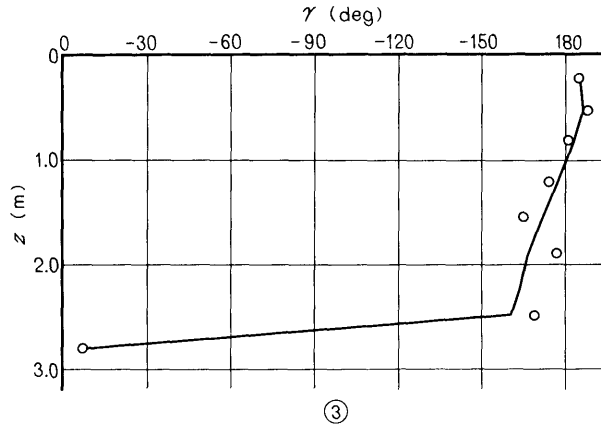
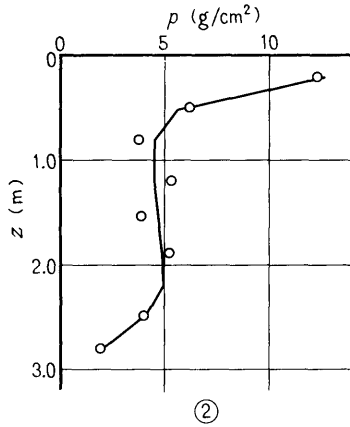
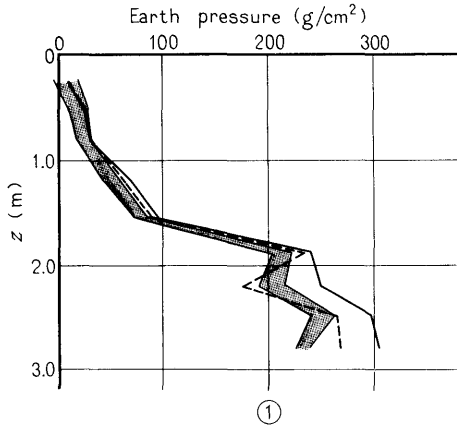

Fig. 39-(42)

II-1-8.32



z m	p g/cm^2	γ deg
0.21	9.7	-170
0.51	8.9	-176
0.81	7.3	-176
1.21	8.9	178
1.54	6.6	180
1.89	8.8	168
2.20	12.6	162

z m	p g/cm^2	γ deg
2.49	10.5	178
2.80	5.6	-47
Bottom (No. 6)	65.6	-25
z m	D mm	λ deg
0	0.439	-29
2.16	0.134	-45
$f =$		8.32 Hz

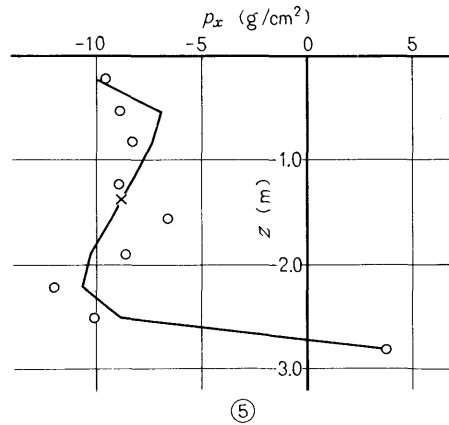
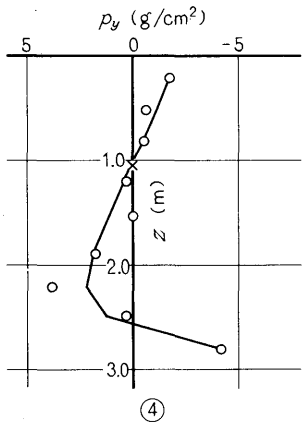
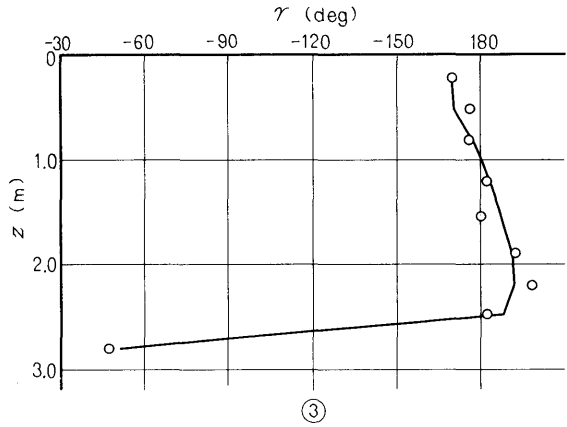
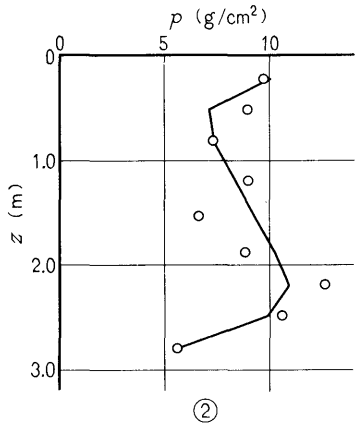
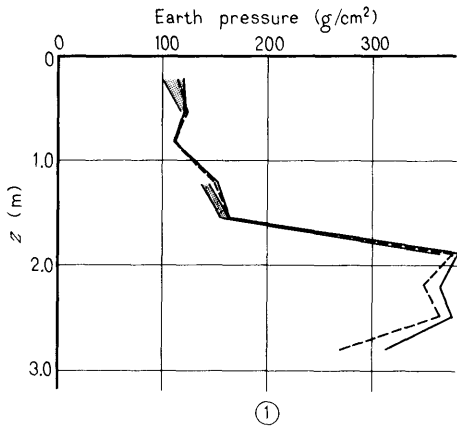

Fig. 39-(43)

II-2-5.15



z m.	p g/cm ²	γ deg
0.21	9.4	175
0.51	3.2	-176
0.81	—	—
1.21	2.8	167
1.54	2.6	-169
1.89	2.6	171
2.20	—	—

z m	p g/cm ²	γ deg
2.49	—	—
2.80	—	—
Bottom (No. 6)	28.9	-13
z m	D mm	λ deg
0	0.0784	11
2.16	0.0289	-6
$f = 5.15$ Hz		

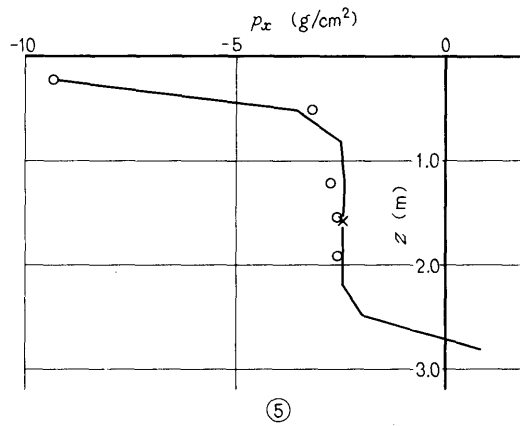
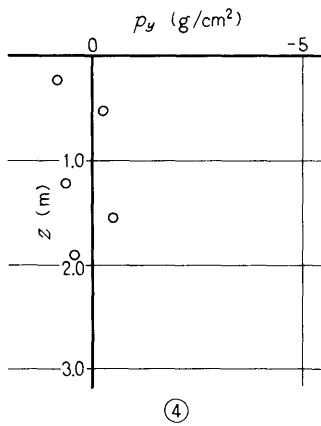
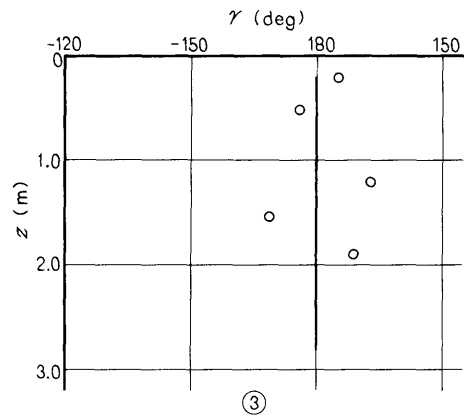
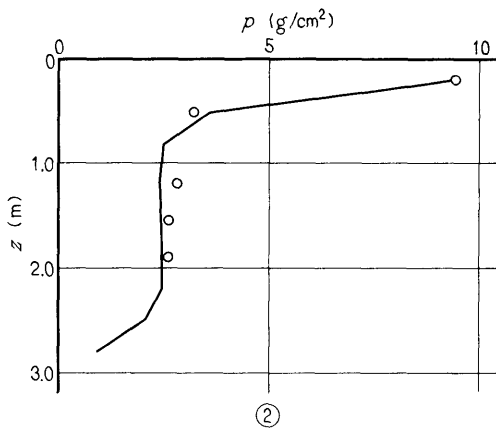

Fig. 39-(44)

II-2-5.40

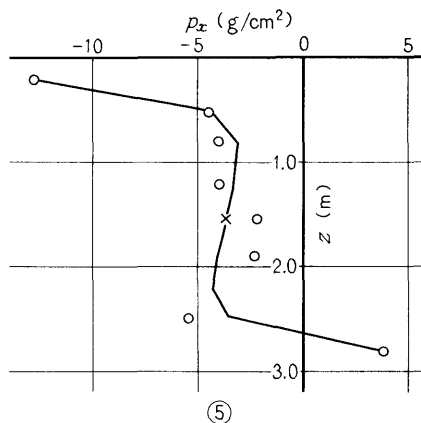
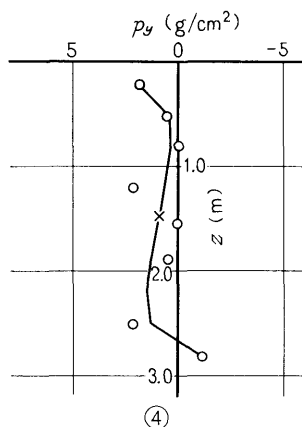
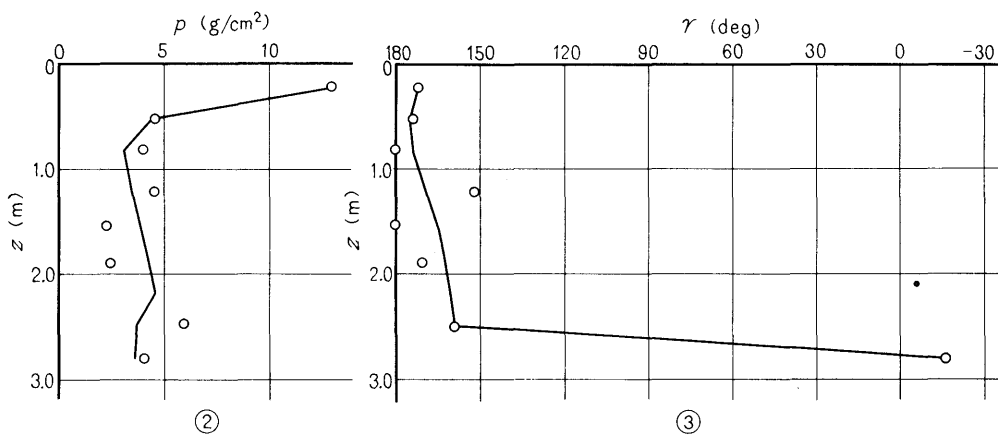
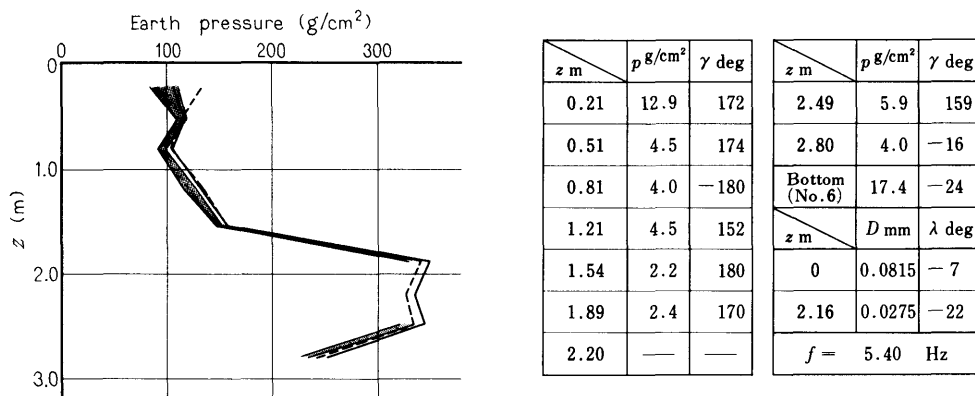
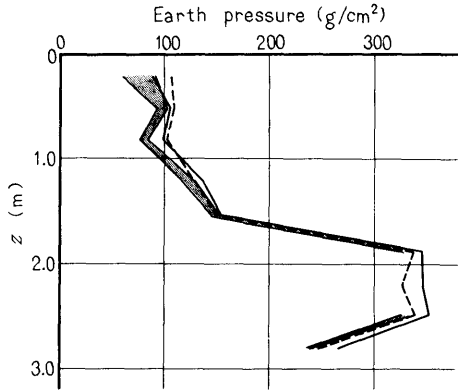

Fig. 39-(45)

II-2-5.91



①

z m	p g/cm ²	γ deg
0.21	15.1	-173
0.51	4.8	-180
0.81	6.2	175
1.21	6.4	177
1.54	3.4	-179
1.89	3.9	170
2.20	—	—

z m	p g/cm ²	γ deg
2.49	4.3	169
2.80	1.5	-18
Bottom (No. 6)	43.6	-19
z m	D mm	λ deg
0	0.119	-11
2.16	0.0414	-27
$f = 5.91$ Hz		

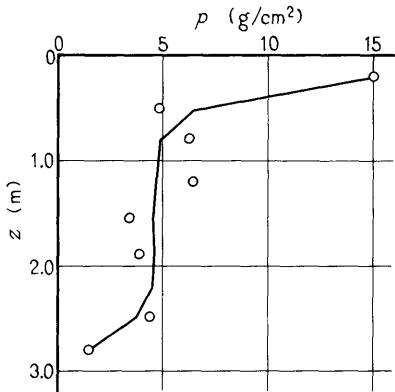

②

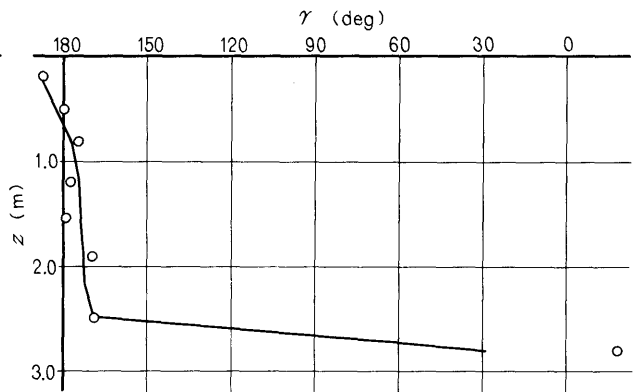

③

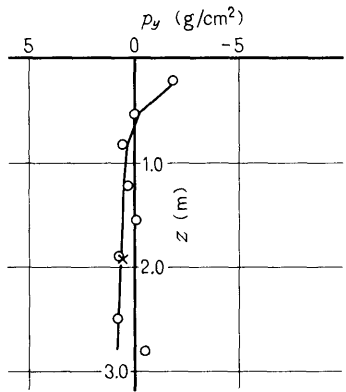

④

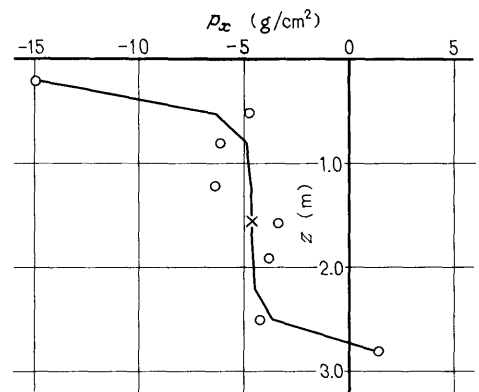

⑤

Fig. 39-(46)

II-2-6.73

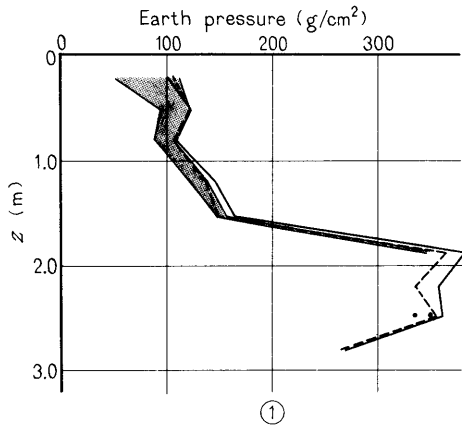

z m	p g/cm^2	γ deg
0.21	32.3	-146
0.51	14.5	-142
0.81	9.0	-156
1.21	7.2	164
1.54	4.8	172
1.89	6.0	156
2.20	—	—

z m	p g/cm^2	γ deg
2.49	6.8	130
2.80	—	—
Bottom (No. 6)	53.5	-76
z m	D mm	λ deg
0	0.140	-57
2.16	0.0502	-86
$f = 6.73$ Hz		

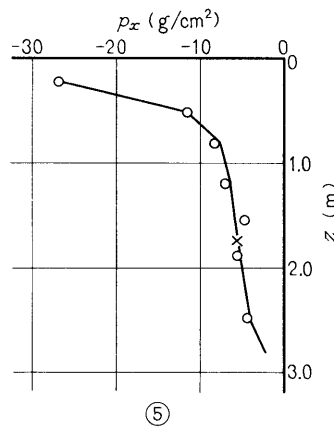
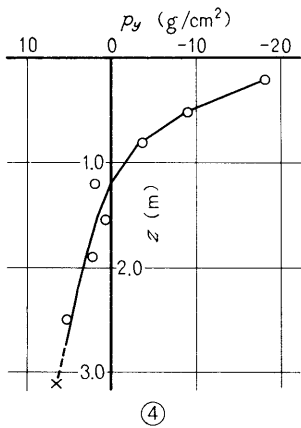
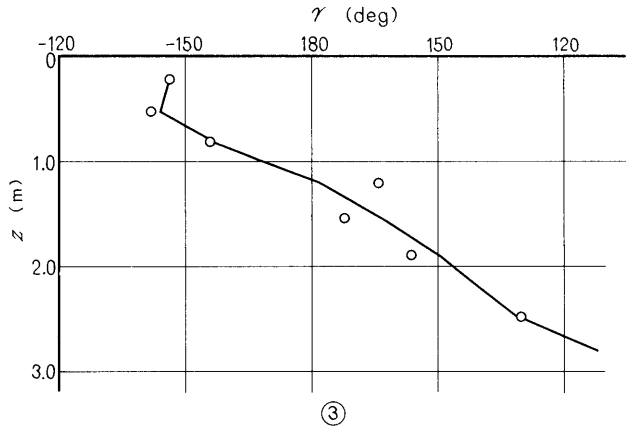
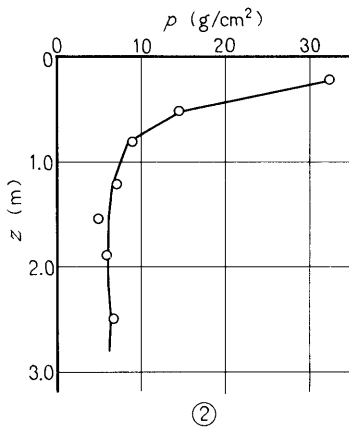
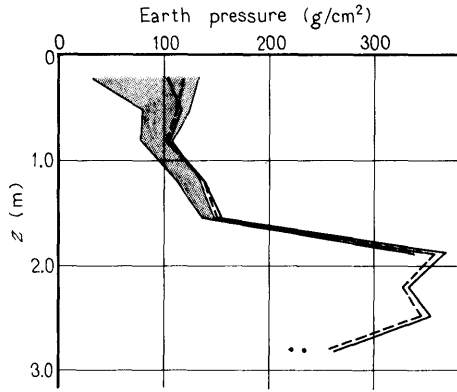

Fig. 39-(47)

II-2-8.38



z m	p g/cm ²	γ deg
0.21	54.1	174
0.51	22.5	174
0.81	14.4	-179
1.21	9.7	166
1.54	5.7	171
1.89	7.6	173
2.20	—	—

z m	p g/cm ²	γ deg
2.49	—	—
2.80	6.5	-10
Bottom (No.6)	9.7	-29
z m	D mm	λ deg
0	0.135	-3
2.16	0.0312	-10
$f = 8.38$ Hz		

①

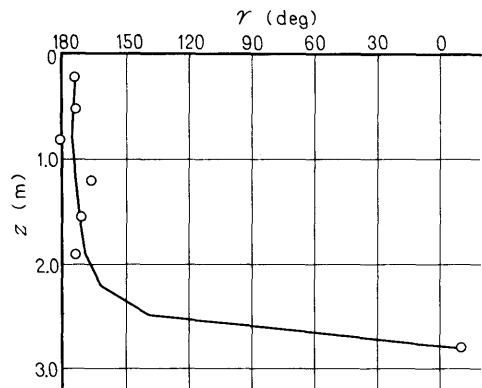
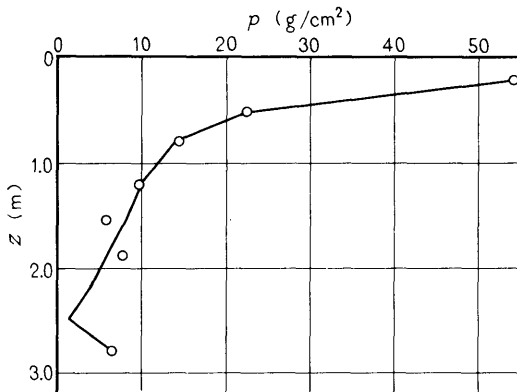

②

③

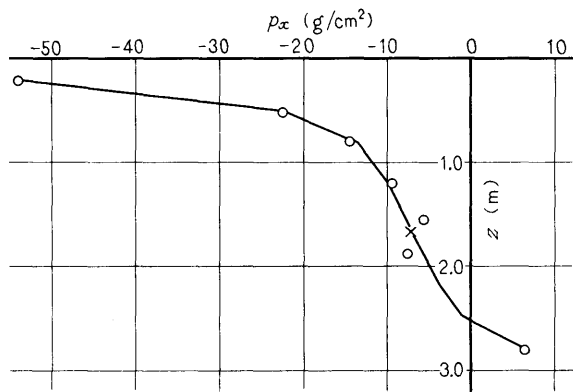
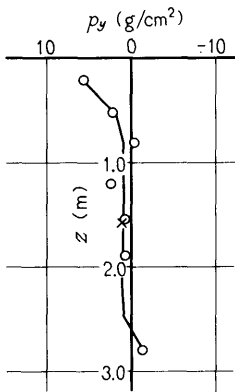

④

⑤

Fig. 39-(48)

II-2-10.4

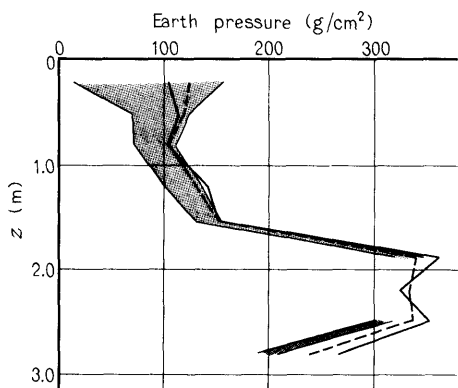

①

z m	p g/cm ²	γ deg
0.21	74.5	152
0.51	26.8	150
0.81	19.8	168
1.21	16.7	169
1.54	11.0	-176
1.89	12.9	-169
2.20	—	—

z m	p g/cm ²	γ deg
2.49	8.0	-133
2.80	9.8	-69
Bottom (No. 6)	69.6	-11
z m	D mm	λ deg
0	0.407	-25
2.16	0.134	-39
$f = 10.4$ Hz		

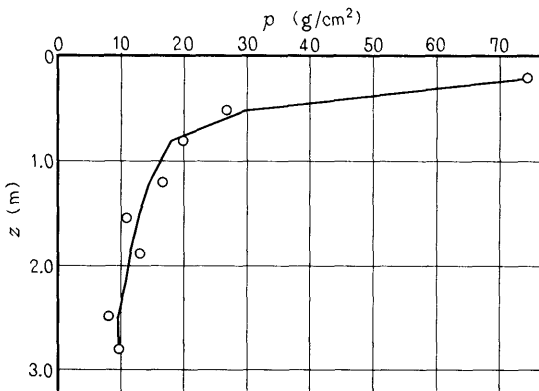

②

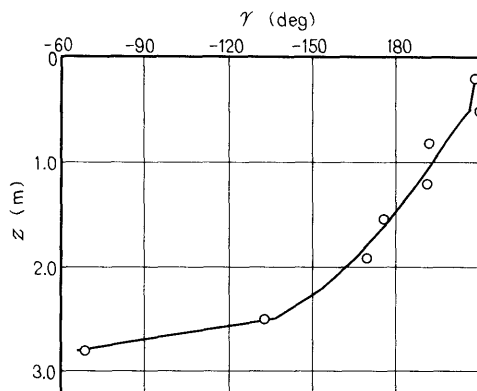

③

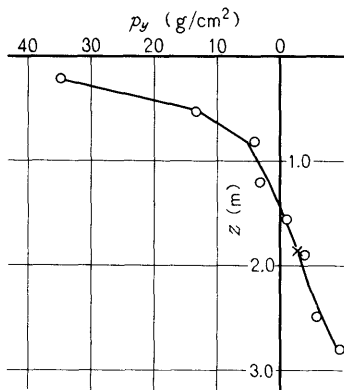

④

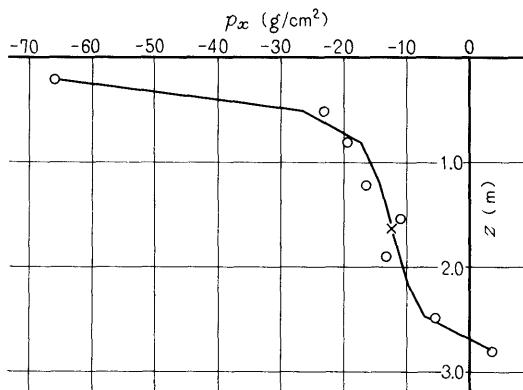

⑤

Fig. 39-(49)