

(19)



(11)

EP 3 495 257 B1

(12)

EUROPEAN PATENT SPECIFICATION

(45) Date of publication and mention of the grant of the patent:
15.04.2020 Bulletin 2020/16

(51) Int Cl.:
B63H 5/16 (2006.01) B63H 1/26 (2006.01)

(21) Application number: **18215036.7**

(22) Date of filing: **26.07.2012**

(54) PROPELLER SETTING SMALL DUCT, AND SHIP

PROPELLEREINSTELLUNG MIT KLEINEM KANAL UND SCHIFF

PETIT CONDUIT DE RÉGLAGE D'HÉLICE ET NAVIRE

(84) Designated Contracting States:
AL AT BE BG CH CY CZ DE DK EE ES FI FR GB GR HR HU IE IS IT LI LT LU LV MC MK MT NL NO PL PT RO RS SE SI SK SM TR

(30) Priority: **26.07.2011 JP 2011163203**

(43) Date of publication of application:
12.06.2019 Bulletin 2019/24

(62) Document number(s) of the earlier application(s) in accordance with Art. 76 EPC:
12817040.4 / 2 738 084

(73) Proprietor: **National Institute of Maritime, Port and Aviation Technology Tokyo 181-0004 (JP)**

(72) Inventors:

- **Sasaki, Noriyuki Mitaka-shi, Tokyo 181-0004 (JP)**
- **Kawashima, Hideki Mitaka-shi, Tokyo 181-0004 (JP)**
- **Fujisawa, Junichi Mitaka-shi, Tokyo 181-0004 (JP)**

(74) Representative: **Körfer, Thomas Mitscherlich PartmbB Patent- und Rechtsanwälte Sonnenstrasse 33 80331 München (DE)**

(56) References cited:
JP-A- H 082 486 JP-A- H09 175 488
JP-A- 2002 220 089 JP-A- 2007 331 549
JP-A- 2011 025 734 US-A- 5 752 865

EP 3 495 257 B1

Note: Within nine months of the publication of the mention of the grant of the European patent in the European Patent Bulletin, any person may give notice to the European Patent Office of opposition to that patent, in accordance with the Implementing Regulations. Notice of opposition shall not be deemed to have been filed until the opposition fee has been paid. (Art. 99(1) European Patent Convention).

Description

[TECHNICAL FIELD]

[0001] The present invention relates to a propeller setting a small duct includes a propeller which is mounted on a stern of a ship's hull and a duct which is provided in front of the propeller, and a ship including a propeller setting the small duct.

[BACKGROUND TECHNIQUE]

[0002] As conventional ducts provided in the vicinity of a propeller, there exist a large duct which covers the propeller and which has a diameter larger than that of the propeller, and an intermediate duct having a diameter slightly smaller than that of the propeller and placed in front of the propeller.

[0003] The large duct covering the propeller is called a ducted propeller, and the large duct is handled as a propulsor which is effective when the large duct is integrally formed on the propeller and a propeller loading is high. This is because that interference between the propeller and the duct is large, and it is more rational to handle, as a propulsor, performance into which this interference is taken.

[0004] On the other hand, the intermediate duct placed in front of the propeller and having a diameter slightly smaller than that of the propeller is handled as an energy-saving device and is not regarded as a propulsor. This is because that interference between the duct and the propeller is not so large, and interference between a ship's hull and the duct is larger than the former interference.

[0005] Therefore, in a performance test of the intermediate duct, a resistance test is carried out in a state where the duct is mounted on the ship's hull. This is based on recognition that the duct is part of the ship's hull.

[0006] Since the ducted propeller has large interference between the large duct and the propeller, efficiency of the ducted propeller is enhanced in an actual sea where a propeller loading increases but the ducted propeller has a problem of cavitation erosion occurred on the inner duct surface, and the large duct is not employed for a large ship almost at all.

[0007] Concerning the intermediate duct, configurations disclosed in Patent Documents 1 to 7 have already been proposed. A further propeller setting a small duct is known from document US 5,752,865.

[0008] Patent Document 1 discloses a duct having a diameter smaller than that of a propeller, and a cross sectional shape of the duct inwardly swells as a convex shape.

[0009] Patent Document 2 discloses a duct having a diameter which is about the same as that of the propeller. A shape of the duct as viewed from a lateral direction is asymmetric with respect to an axis of the duct. A cross sectional shape of the duct inwardly swells as a convex

shape, and a projecting degree of an upstream side of this as the convex shape is greater than those of other portions.

[0010] Patent Document 3 discloses a duct which is asymmetric with respect to its axis as viewed from a side of the duct, a diameter of a rear end of the duct is 50% to 80% of a diameter of a propeller, and a horizontal distance between a rear end surface of the duct and an outer peripheral tip end of the propeller is 10% to 30% of a diameter of the propeller.

[0011] Each of Patent Documents 4 to 7 discloses a duct which is asymmetric with respect to its axis as viewed from a side of the duct, and a diameter of the duct is smaller than that of a propeller.

[0012] Patent Document 7 discloses a propulsor in which a pitch of a blade root of a propeller is slightly larger, a pitch of a central portion is reduced, and a pitch of a blade tip is again increased.

[PRIOR ART DOCUMENT]

[PATENT DOCUMENTS]

[0013]

[Patent Document 1] Japanese Patent Application Laid-open No.H9-175488

[Patent Document 2] Japanese Examined Utility Model Publication No.S56-32396

[Patent Document 3] Japanese Utility Model Application No.H2-20180 (microfilm of contents of specification and drawings attached to application form of Japanese Utility Model Application Laid-open No.H3-17996) (issued by Japanese Patent Office on February 21, 1991)

[Patent Document 4] Japanese Patent Application Laid-open No.2008-143488

[Patent Document 5] Japanese Patent Application Laid-open No.2007-331549

[Patent Document 6] Japanese Patent Application Laid-open No.2002-220089

[Patent Document 7] Japanese Patent Application Laid-open No.H10-264890

[SUMMARY OF THE INVENTION]

[PROBLEM TO BE SOLVED BY THE INVENTION]

[0014] However, since the intermediate duct placed in front of the propeller has weak interference with respect to the propeller, the above-described effect as that of the ducted propeller can not be expected so much in the actual sea where a propeller loading is increased by wind and waves.

[0015] The intermediate duct disclosed in each of the Patent Documents does not optimize a load distribution of the propeller in a radial direction which governs efficiency using interference with respect to the duct. Fur-

ther, the ducted propeller in which interference can be expected has the problem of cavitation erosion, and it is difficult to employ the large duct in a large ship having a large diameter propeller.

[0016] According to Patent Document 7, since the pitch at the blade tip of the propeller is increased, cavitation in the blade tip of the propeller is increased.

[0017] Hence, it is an object of the present invention, as the energy-saving device having characteristics of both the large duct and the intermediate duct, to contrive a shape of the propeller, to place a small duct in front of and close to the propeller, to suppress cavitation in an actual sea where a propeller loading is increased, and to optimize a load distribution of the propeller in a radial direction which governs efficiency using interference with respect to the small duct.

[MEANS FOR SOLVING THE PROBLEM]

[0018] According to the invention, there is provided a propeller setting a small duct according to claim 1. Further preferred embodiments are defined in the dependent claims.

[0019] A first aspect provides a propeller setting a small duct includes a propeller which is mounted on a stern of a ship's hull and a duct which is provided in front of the propeller, wherein a diameter of the duct is set to 20% or more and 50% or less of a diameter of the propeller, and a pitch of the propeller is a decreasing pitch which reduces in a radial direction of the propeller, and which becomes a maximum value at a blade root of the propeller and becomes a minimum value at a blade tip of the propeller. According to this aspect, the duct is combined with the decreasing pitch propeller, the diameter of the duct is set to 20% or more and 50% or less of that of the propeller. According to this, the duct can be brought close to the propeller without generating cavitation. By decreasing the pitch of the propeller, a suction effect at the center portion of the propeller is enhanced in an actual sea where a propeller loading is increased by wind and waves, and it is possible to optimize a load distribution of the propeller in the radial direction which governs efficiency using interference with respect to the duct. By bringing the propeller pitch into the maximum value at the blade root of the propeller, and by bringing the propeller pitch into the minimum value at the blade tip, it is possible to suppress the cavitation generated at the blade tip of the propeller. According to the first aspect, since the diameter of the duct is set to 20% or more and 50% or less of the diameter of the propeller, the total system of propulsor is small in size and light in weight, and has small frictional resistance, low vibration, low noise and low cost, and it is possible to enhance the propulsive efficiency.

[0020] According to a second aspect of the invention, in the propeller setting the small duct of the first aspect, the maximum value of the pitch is set to 120% or more and 160% or less of the minimum value of the pitch. Ac-

ording to this aspect, it is possible to enhance the suction effect at the center portion of the propeller, and an optimal load distribution can be obtained.

[0021] According to the invention, a distance between a rear end of the duct and a front edge of the propeller is set to 0.5% or more and 15% or less of the diameter of the propeller. Thus, the duct can be brought close to the propeller without generating separation caused by the suction effect of the decreasing pitch propeller, and it is possible to enhance the interference effect between the duct and the propeller.

[0022] According to a fourth aspect of the invention, in the propeller setting the small duct of any one of the first to third aspects, a cross sectional shape of the duct is formed as a convex shape which swells inward, a projecting degree of the convex shape is greater on an upstream side of the duct, and a camber ratio is set to 6% or more and 16% or less. According to this aspect, even if the camber ratio is set to 6% or more and 16% or less, it is possible to increase the lift force for driving the ship's hull forward as component force without generating separation caused by the suction effect at the center portion of the propeller.

[0023] According to a fifth aspect of the invention, in the propeller setting the small duct of any one of the first to fourth aspects, the duct is an acceleration type duct in which an inner diameter of the duct on its downstream side is smaller than an inner diameter of the duct on its upstream side. According to this aspect, it is possible to further enhance the suction effect at the center portion of the propeller and the lift force for driving the ship's hull forward as the component force.

[0024] According to a sixth aspect of the invention, in the propeller setting the small duct of any one of the first to fifth aspects, a center of the duct matches with an axis of the propeller. According to this aspect, it is possible to easily produce and install the duct and to inexpensively provide the duct, as compared with a duct which is asymmetric with respect to its axis, a duct which is installed such that a center shaft of the duct is offset from a propeller shaft, or a duct which is installed with inclination angle.

[0025] According to a seventh aspect of the invention, in the propeller setting the small duct of any one of the first to sixth aspects, the duct is mounted on a stern tube of the ship's hull or a ship's hull end which covers the stern tube through a strut. According to this aspect, it is possible to take in the flow from the entire front surface, to increase the interference with respect to the propeller, to enhance the efficiency, and to easily retrofit the duct.

[0026] According to an eighth aspect of the invention, in the propeller setting the small duct of any one of the first to seventh aspects, an inner surface of the duct has a fixed blade which forms a flow into the propeller as a counterflow. According to this aspect, a flow which flows into the duct flows into the propeller as counterflow by the fixed blade, and this counterflow further enhances the propeller efficiency.

[0027] According to a ninth aspect of the invention, in the propeller setting the small duct of the eighth aspect, the strut also functions as the fixed blade, and the strut is twisted in a direction opposite from a rotation direction of the propeller. According to this aspect, the flow is rotated by the strut, the strut also functions as a fixed blade, and a structure is simplified.

[0028] A tenth aspect of the invention provides a ship comprising the propeller setting the small duct according to any one of the first to ninth aspects. According to this aspect, it is possible to provide a ship having high propulsive efficiency in an actual sea where a propeller loading is increased.

[EFFECT OF THE INVENTION]

[0029] According to the propeller setting the small duct of the present invention, the duct can be reduced in size by combining the duct and the decreasing pitch propeller with each other, and if the diameter of the duct is set to 20% or more and 50% or less of the diameter of the propeller, the duct can be brought close to the propeller without generating cavitation. Therefore, if the pitch of the propeller is made as the decreasing pitch, it is possible to enhance the suction effect at the center portion of the propeller in an actual sea where the propeller loading is increased by wind and waves, the load distribution of the propeller in the radial direction which governs efficiency can be optimized by utilizing interference with respect to the duct. By bringing the propeller pitch into the maximum value at the blade root of the propeller, and by bringing the propeller pitch into the minimum value at the blade tip, it is possible to suppress the cavitation generated at the blade tip of the propeller.

[0030] According to the propeller setting the small duct of the present invention, since the diameter of the duct is set to 20% or more and 50% or less of the diameter of the propeller, the propeller is small in size and light in weight, and has small frictional resistance, low vibration, low noise and low cost, and it is possible to enhance the propulsive efficiency.

[0031] If the maximum value of the pitch is set to 120% or more and 160% or less of the minimum value, it is possible to enhance the suction effect at the center portion of the propeller, and to make the load distribution optimal.

[0032] If the distance between the rear end of the duct and the front edge of the propeller is set to 0.5% or more and less than 10% of the diameter of the propeller, it is possible to bring the duct close to the propeller without generating the separation caused by the suction effect of the decreasing pitch propeller, and to enhance the interference effect between the duct and the propeller.

[0033] If the cross sectional shape of the duct is formed as a convex shape which swells inward, the projecting degree of the convex shape is greater on the upstream side of the duct, and the camber ratio is set to 6% or more and 16% or less, the separation is not generated by the

suction effect at the center portion of the propeller even if the camber ratio is set to 6% or more and 16% or less, and it is possible to increase the lift force of driving the ship's hull forward as the component force.

[0034] If the duct is made as an acceleration type duct which has a downstream inner diameter smaller than an upstream inner diameter, it is possible to further enhance the suction effect at the center portion of the propeller and the lift force for driving the ship's hull forward as the component force.

[0035] If the center of the duct and the axis of the propeller match with each other, it is possible to easily produce and install the duct and to inexpensively provide the duct, as compared with a duct which is asymmetric with respect to its axis, a duct which is installed such that a center shaft of the duct is offset from a propeller shaft, or a duct which is installed with inclination angle.

[0036] If the duct is mounted on a stern tube of the ship's hull or an end of the ship's hull which covers the stern tube through the strut, it is possible to take in a flow from the entire of a front opening, to enhance the interference with respect to the propeller, to enhance the efficiency, and to easily retrofit the duct.

[0037] If an inner surface of the duct has a fixed blade which forms a flow into the propeller as a counterflow, the flow which flows into the duct flows into the propeller by the fixed blade as the counterflow, and it is possible to further enhance the propeller efficiency.

[0038] If the strut also functions as the fixed blade and the strut is twisted in a direction opposite from a rotation direction of the propeller, the flow is rotated by the strut, the strut also functions as the fixed blade, and a structure is simplified.

[0039] According to the ship of the present invention, it is possible to provide a ship having high propulsive efficiency especially in an actual sea where a propeller loading is increased.

[BRIEF DESCRIPTION OF THE DRAWINGS]

[0040]

Fig. 1 is a schematic diagram showing a configuration of a ship provided with a propeller setting a small duct according to an embodiment of the present invention;

Figs. 2 are partial sectional side view and a sectional view taken along a line A-A showing essential portions of a propeller setting a small duct used for the ship;

Figs. 3 are partial sectional views showing a configuration of essential portions of another propeller setting a small duct used for the ship;

Fig. 4 is a graph showing pitch distributions of a decreasing pitch propeller and a normal propeller;

Fig. 5 is a graph showing flow speed distributions of the decreasing pitch propeller and the normal propeller;

Fig. 6 is a graph showing a flow speed distribution according to a distance between a rear end of the duct and a front edge of the propeller setting the small duct;

Fig. 7 is a graph showing a result of a propeller loading changing test in which decrease in speed of the ship during waves is simulated; and

Fig. 8 is a graph showing a result of a propeller loading changing test in which decrease in speed of the ship during waves is simulated.

[EXPLANATION OF SYMBOLS]

[0041]

1 ship's hull
 1a ship's hull end
 10 propeller
 10b stern tube
 11 boss
 20 duct
 20a, 20b, 20c, 20d strut (fixed blade)
 Dp diameter of propeller
 Ddin diameter of front edge of duct
 Ddout diameter of rear end of duct
 H pitch
 L distance between rear end of duct and front edge of propeller

[MODE FOR CARRYING OUT THE INVENTION]

[0042] A propeller setting a small duct according to an embodiment of the present invention will be described below.

[0043] Fig. 1 is a schematic diagram showing a configuration of a ship provided with a propeller setting a small duct according to the embodiment of the invention, Fig. 2 (a) is a partial sectional side view showing essential portions of a propeller setting a small duct used for the ship, Fig. 2(b) is a sectional view taken along a line A-A in Fig. 2(a), Figs. 3 are partial sectional views showing a configuration of essential portions of another propeller setting a small duct used for the ship, Fig. 4 is a graph showing pitch distributions of a decreasing pitch propeller and a normal propeller, Fig. 5 is a graph showing flow speed distributions of the decreasing pitch propeller and the normal propeller, and Fig. 6 is a graph showing a flow speed distribution generated by a distance between a rear end of the duct and a front edge of the propeller setting the small duct.

[0044] As shown in Fig. 1, the ship includes a propeller 10 mounted on a stern of a ship's hull 1, and a duct 20 mounted in front of the propeller 10.

[0045] As shown in Fig. 2(a), the propeller 10 is provided at its center portion with a boss 11. The duct 20 is an acceleration type duct in which an inner diameter of a rear end 22 located downstream is smaller than that of the front end 21 located upstream.

[0046] A cross sectional shape of the duct 20 swells inward as a convex shape 23, and a projecting degree of the convex shape 23 is greater upstream of the duct 20. A camber ratio in the maximum camber position is set to 6% or more and 16% or less. Generally, if the camber ratio exceeds 8%, separation is generated in the duct 20, but the small duct 20 specified in the embodiment is provided in front of and close to the propeller 10, and a pitch of the propeller 10 is a decreasing pitch which reduces in the radial direction. Therefore, even if the camber ratio exceeds 8% by a suction effect at the center portion of the propeller 10, it is possible to increase a lift force without generating the separation. By making the duct 20 as the acceleration type duct and by swelling the cross sectional shape inwardly as the convex shape 23 to increase the camber ratio, it is possible to accelerate a flow, to increase interference with respect to the propeller 10, and to also increase the lift force which drives the ship's hull 1 forward as a component force.

[0047] A diameter of the propeller 10 is defined as Dp, a diameter of the front end 21 of the duct 20 is defined as Ddin, a diameter of the rear end 22 of the duct 20 is defined as Ddout and a distance between the front edge of the propeller 10 and the rear end 22 of the duct 20 is defined as L. It is preferable that the diameter Ddin of the front end 21 of the duct 20 is 50% or less of the diameter Dp of the propeller 10, the distance L between the rear end 22 of the duct 20 and the front edge of the propeller 10 is 15% or less or less than 10% of the diameter Dp of the propeller 10. It is preferable that the distance L between the rear end 22 of the duct 20 and the front edge of the propeller 10 is as short as possible, but to avoid contact between the duct 20 and the propeller 10, it is preferable that the distance L is set to 0.5% or more of the diameter Dp of the propeller 10.

[0048] The diameter Ddin of the front end 21 of the duct 20 and the diameter Ddout of the rear end 22 of the duct 20 are set to 20% or more and 50% or less of the diameter Dp of the propeller 10. In a range of 20% or more and 50% or less of the diameter Dp of the propeller 10, the duct 20 may be of a cylindrical shape in which the diameter Ddin of the front end 21 of the duct 20 and the diameter Ddout of the rear end 22 of the duct 20 are equal to each other. It is more preferable that the diameter Ddin of the front end 21 of the duct 20 is greater than the diameter Ddout of the rear end 22 of the duct 20. It is more preferable that the diameter Ddin of the front end 21 of the duct 20 is 35% or more and 50% or less of the diameter Dp of the propeller 10, and the diameter Ddout of the rear end 22 of the duct 20 is 20% or more and less than 40% of the diameter Dp of the propeller 10.

[0049] If the diameter Ddout and the diameter Ddin of the duct 20 is set to 20% or more and 50% or less of the diameter Dp of the propeller 10, the propeller 10 is small in size and light in weight, and has small frictional resistance, low vibration, low noise and low cost, and it is possible to enhance the propulsive efficiency.

[0050] To enhance the interference effect and to pre-

vent the duct from abutting against the stern and to prevent resistance from increasing, it is preferable that a width W (length) of the duct 20 is 20% or more and 60% or less of the diameter D_p . To widely apply the present invention to general ships including large ships, it is more preferable that the width W of the duct 20 is 25% or more and 50% or less of the diameter D_p .

[0051] As shown in Fig. 2(a), the duct 20 is formed symmetrically with respect to its axis. Since the duct 20 is mounted such that a drive shaft 10a of the propeller 10 and a center shaft of the duct 20 match with each other, it is possible to easily produce and install the duct 20 and to inexpensively provide the duct 20 as compared with a duct which is asymmetric with respect to its axis, a duct which is installed such that a center shaft of the duct is offset from a propeller shaft, or a duct which is installed with inclination angle.

[0052] As shown in Fig. 2(b), the duct 20 is mounted on a ship's hull end 1a which covers a stern tube 10b by struts 20a, 20b, 20c and 20d. The stern tube 10b is provided around the drive shaft 10a of the propeller 10. In the case of a ship whose stern tube 10b is exposed, the duct 20 may be mounted directly on the stern tube 10b by the struts 20a, 20b, 20c and 20d. In the case of a ship whose stern tube 10b is partially exposed, the duct 20 may be mounted on both the stern tube 10b and the ship's hull end 1a by the struts 20a, 20b, 20c and 20d.

[0053] If the duct 20 is mounted on the stern tube 10b of the ship's hull 1 or the ship's hull end 1a which covers the stern tube 10b through the struts 20a, 20b, 20c and 20d, it is possible to take in a flow from the entire of a front opening, to enhance the interference with respect to the propeller 10, to enhance the efficiency, and to easily retrofit the duct 20. This configuration has a merit when the duct 20 is retrofitted on an existing ship, but when the duct 20 is mounted on a new ship also, there is a merit because it is unnecessary to machine an outer plate of the ship's hull 1 unlike the conventional technique.

[0054] The struts 20a, 20b, 20c and 20d are radially connected to the center shaft of the duct 20 and especially, an angle between the struts 20a and 20d is set smaller than an angle between the struts 20b and 20c. According to this configuration, a wake distribution can be enhanced.

[0055] It is preferable that the minimum number of the struts is two and the maximum number is five, and it is possible to provide more struts outside the duct 20.

[0056] A cross section of a flow path of the duct 20 is configured such that the diameter D_{dout} of the rear end 22 is smaller than the diameter D_{din} of the front end 21. If the cross section of a flow path of the duct 20 is narrowed toward the downstream, it is possible to enhance the wake distribution. To narrow the flow path cross section of the duct 20, it is possible to increase the cross sectional areas of the struts 20a, 20b, 20c and 20d toward the downstream instead of narrowing an inner cross section of the duct 20. By enhancing the wake distribution, it is possible to further enhance the propeller efficiency

by the small duct 20.

[0057] As shown in Figs. 3, it is also possible to provide a strut 20e having a twist on an inner surface of the duct 20, and to form a flow toward the propeller 10 as a counterflow. In this case, it is preferable that a mounting angle with respect to a center line of the ship's hull is 5° to 25° on the stern tube side θ_s , and is 5° to 10° on the inner surface side θ_d of the duct 20. A flow flowing into the duct 20 is accelerated from the upstream toward the downstream, the flow is rotated in a direction opposite from the rotating direction of the propeller 10 by the strut 20e having the twist, this flow flows into the propeller 10 as a counterflow, and the propeller efficiency is further enhanced.

[0058] It is possible to provide the strut 20e outside the duct 20, and a fixed blade which rotates the flow may be provided on an inner surface of the duct 20, but since the strut 20e rotates the flow, the strut 20e functions as the fixed blade, and a structure is simplified.

[0059] Fig. 4 shows pitch distributions of a decreasing pitch propeller and a normal propeller.

[0060] In the propeller 10, a radius of the boss 11 is r_1 , and the blade root is r_1 to r_2 . A radius R is $1/2 D_p$, and H represents a pitch. The blade root is 20% or more and 40% or less of the diameter D_p of the propeller 10.

[0061] The pitch H of the propeller 10 of this embodiment is a decreasing pitch in which the pitch H becomes the maximum at the blade root of the propeller 10 and the pitch H becomes the minimum value at the blade tip in the direction of radius R . Comparative example shown in Fig. 4 shows a constant pitch.

[0062] The pitch H of the propeller 10 of the embodiment becomes the maximum value H_{max} at the blade root (r_1 to r_2) of the propeller 10, and the maximum value H_{max} is set to 120% or more and 160% or less of the minimum value H_{min} of the pitch H while taking, into consideration, propulsion efficiency and suppression of generation of cavitation.

[0063] Fig. 5 shows flow speed distributions of the propeller of the decreasing pitch according to the embodiment shown in Fig. 4 and a normal propeller as comparative example.

[0064] In Fig. 5, V represents flow speed on the inflow side of the propeller 10, V_x represents flow speed on the outflow side of the propeller 10, and both V and V_x show flow speed in the axial direction.

[0065] As shown in Fig. 5, in the embodiment, the flow speed distribution is enhanced when r_1/R is 0.2 to 0.6 as compared with comparative example.

[0066] That is, in Fig. 5, since the pitch of the propeller 10 is the decreasing pitch, the flow speed distribution in the vicinity of the center (blade root) of the propeller 10 is improved, and this suggests that the duct 20 may be a small duct 20 having a small diameter D_{din} . Since the duct 20 can be made small, it is possible to increase the flow speed of the blade root of the propeller 10, the pitch of the propeller 10 in the blade root is increased, and interference can be enhanced. Therefore, it is possible

to inexpensively produce a light-weighted propeller, and since a surface area is small, frictional resistance can be reduced. Since the duct 20 is small in size, flow speed at the blade root of the propeller 10 which is relatively slow in speed is increased. Therefore, it is possible to restrain cavitation from being generated, and to prevent the propeller 10 from being damaged and it is possible to avoid vibration and noise of the propeller 10. Further, the pitch of the propeller 10 is the decreasing pitch in which the propeller pitch is reduced in the radial direction, the propeller pitch becomes the maximum at the blade root and becomes the minimum at the blade tip. Therefore, it is also possible to suppress cavitation which is generated at the blade tip of the propeller 10.

[0067] Fig. 6 shows a flow speed distribution when the distance L between the rear end 22 of the duct 20 and the front edge of the propeller 10 of the propeller setting the small duct is changed.

[0068] When the distance L is 15% or less of the diameter D_p of the propeller 10, interference between the propeller 10 and the duct 20 appears remarkably, and if the distance L is made less than 10% of D_p , a load distribution in the direction of radius R of the propeller 10 is largely influenced. If the distance L is too long, the duct 20 abuts against the ship's hull 1. If the distance L is less than 10% of D_p , it is possible to prevent the duct 20 from abutting against the ship's hull 1, and it is possible to avoid a case where it becomes difficult to take in a flow from the entire of the front opening .

[0069] Figs. 7 and 8 show results of a propeller loading changing test in which decrease in speed of the ship during waves is simulated.

[0070] Fig. 7 is a graph showing the propulsion efficiency when the distance between the front edge of the propeller and the rear end of the duct is changed and when the duct is not provided. Fig. 8 is a graph showing the propulsion variation when the distance between the front edge of the propeller and the rear end of the duct is changed.

[0071] In this experiment, a tested ship is an Aframax tanker (Lpp (length between perpendicular lines) is 229 m, B (width of ship) is 42 m and D (depth of ship) is 12.19 m). A model ship of Lpp = 4.8600 m, B = 0.8914 m and D = 0.2587 m was used.

[0072] A propeller 10 of the tested ship had such sizes that D_p (diameter of propeller) is 7 m, H/D (0.7 R) (pitch position) is 0.67, EAR (expanded area ratio) is 0.45, Rake (inclination of blade) is -216.7 mm, Z (number of blades) is four, Boss Ratio is 0.1586, and Skew (warpage of blade) is 20 degrees. A propeller having such sizes that D_p is 0.148559 m, H/D (0.7 R) is 0.67, EAR is 0.45, Rake is -4.6 mm, Z is four, Boss Ratio is 0.1586 and Skew is 20 degrees was used as a model propeller.

[0073] According to the duct 20 used in the experiment, D_{din} (diameter of front end 21) is 48% of D_p , D_{dout} (diameter of rear end 22) is 40% of D_p , length (width) W of duct 20 is 24% of D_p , and a camber ratio of duct blade is 8%.

[0074] In this experiment, to simulate decrease in speed of the ship during waves, a self-navigation test was carried out in a state where the speed of the ship was decreased while keeping the number of rotation was maintained constant, and a propeller loading was increased.

[0075] In Fig. 7, a lateral axis shows a ship speed ratio, a vertical axis shows propulsion efficiency, and the propulsion efficiencies when the ship speed ratio is reduced to 0.75 are compared with each other.

[0076] In Example 1, the distance L between the front edge of the propeller 10 and the rear end 22 of the duct 20 is $D_p \times 6\%$. In Example 2, L is $D_p \times 3\%$. In Example 3, L is $D_p \times 1\%$. In comparative example, the duct 20 is not used.

[0077] In Examples 1 to 3, propulsion efficiencies are superior to that of comparative example in a range of the ship speed ratio from 0.75 to 1.

[0078] In Fig. 8, a lateral axis shows a propeller thrust force, a vertical axis shows duct resistance (thrust force), and thrust forces when the propeller thrust force is varied between 1.05 and 1.3 are compared with each other.

[0079] In Example 2, the thrust force is higher than that of Example 1, and the thrust force of Example 3 is higher than that of Example 2.

[0080] As shown in Fig. 8, the smaller the distance L between the front edge of the propeller 10 and the rear end 22 of the duct 20 is, the higher the thrust force becomes.

[0081] According to the propeller setting a small duct, of the embodiment, which includes the propeller 10 mounted on the stern of the ship's hull 1 and the duct 20 mounted in front of the propeller 10, since the duct 20 is combined with the decreasing pitch propeller 10, the duct 20 can be made small, the diameter D_{din} of the duct 20 can be made 20% or more and 50% or less of the diameter D_p of the propeller 10, and it is possible to bring the duct 20 close to the propeller 10 without generating cavitation. Therefore, the pitch H of the propeller 10 is the decreasing pitch in which the pitch H becomes the maximum value at the blade root of the propeller 10 and becomes the minimum value at the blade tip. According to this, it is possible to enhance the suction effect at the center portion of the propeller 10 in an actual sea where a propeller loading 10 is increased by the wind and waves, the load distribution in the radial direction of the propeller 10 which governs the efficiency is optimized by utilizing interference with respect to the duct 20. Since the pitch H of the propeller 10 is the maximum value at the blade root of the propeller 10 and is the minimum value at the blade tip, it is possible to suppress cavitation which is generated at the blade tip of the propeller 10. Therefore, it is possible to prevent the propulsion efficiency from reducing, to prevent noise and vibration from being generated, and to prevent the propeller 10 from being damaged.

[0082] According to the propeller setting the small duct of the embodiment, since the diameter of the duct 20 is

set to 20% or more and 50% or less of the diameter D_p of the propeller 10, the flow speed of the blade root of the propeller 10 is increased, the pitch of the propeller 10 in the blade root is increased, interference is increased, and the propulsive efficiency can be enhanced. It is possible to realize an inexpensive propeller 10 which is small in size and light in weight, and which has small frictional resistance, low vibration and low noise.

[0083] According to the propeller setting the small duct of the embodiment, the maximum value H_{max} of the pitch H is set to 120% or more and 160% or less of the minimum value H_{min} of the pitch H . According to this, generation of cavitation is suppressed, the suction effect at the center portion of the propeller 10 is enhanced to optimize the load distribution, and the propulsion efficiency can be enhanced.

[0084] According to the propeller setting the small duct of the embodiment, the distance L between the rear end 22 of the duct 20 and the front edge of the propeller 10 is set to 0.5% or more and less than 10% of the diameter D_p of the propeller 10. According to this, the front end 21 of the duct is prevented from coming into contact with the ship's hull 1 of the stern, a flow is taken in from the entire front surface of the duct 20, and the interference effect between the duct 20 and the propeller 10 can be enhanced.

[0085] According to the propeller setting the small duct of the embodiment, the duct 20 is formed as the acceleration type duct in which the inner diameter on the downstream side is smaller than the inner diameter on the upstream side. According to this, a flow can be accelerated, and the suction effect at the center portion of the propeller 10 can further be enhanced.

[0086] According to the propeller setting the small duct of the embodiment, the center of the duct 20 matches with the axis of the propeller 10. Therefore, it is possible to easily produce and install the duct and to inexpensively provide the duct.

[0087] According to the propeller setting the small duct of the embodiment, the duct 20 is mounted on the stern tube 10b of the ship's hull 1 or the ship's hull end 1a which covers the stern tube 10b through the struts 20a, 20b, 20c and 20d. Therefore, it is possible to take in a flow from the entire of the front opening, to enhance the interference with respect to the propeller 10, to enhance the efficiency, and to easily retrofit the duct 20 to an existing ship.

[0088] According to the propeller setting the small duct of the embodiment, the cross sectional shape of the duct 20 is formed as the convex shape 23 which swells inward, a projecting degree of the convex shape 23 is greater on the upstream side of the duct 20, and the camber ratio is set to 6% or more and 16% or less. Therefore, a flow on the upstream side where the average speed is slow can be accelerated, increase in resistance is suppressed, and the suction effect at the center portion of the propeller 10 can further be enhanced. In this case, even if the camber ratio is set high, i.e., 6% or more and 16% or less by

the suction effect, it is possible to increase the lift force for driving the ship's hull 1 forward without generating the separation.

[0089] If the propeller setting the small duct of the embodiment is provided, it is possible to provide a ship having high propeller efficiency in an actual sea where a propeller loading is increased.

[INDUSTRIAL APPLICABILITY]

[0090] According to the propeller setting the small duct of the present invention, the propeller is small in size and light in weight, and has small frictional resistance, low vibration and low noise, and it is possible to inexpensively enhance the propulsive efficiency, and the propeller can widely be applied to general ships including large ships.

Claims

1. A propeller setting a small duct includes a propeller (10) mounted on a stern of a ship's hull and a duct (20) provided in front of the propeller (10),
characterized in that
a diameter of the duct (20) is set to 20% or more and 50% or less of a diameter (D_p) of the propeller (10), and
a pitch (H) of the propeller (10) is a decreasing pitch which reduces in a radial direction of the propeller (10), and which becomes a maximum value at a blade root of the propeller and becomes a minimum value at a blade tip of the propeller,
and a distance (L) between a rear end of the duct (20) and a front edge of the propeller (10) is set to 0.5% or more and 15% or less of the diameter (D_p) of the propeller (10) of which interference becomes remarkable.
2. The propeller setting the small duct according to claim 1,
wherein the maximum value of the pitch is set to 120% or more and 160% or less of the minimum value of the pitch.
3. The propeller setting the small duct according to claim 1 or 2,
wherein a cross sectional shape of the duct is formed as a convex shape which swells inward, a projecting degree of the convex shape is greater on an upstream side of the duct, and a camber ratio is set to 6% or more and 16% or less.
4. The propeller setting the small duct according to any one of claims 1 to 3,
wherein the duct is an acceleration type duct in which an inner diameter of the duct on its downstream side is smaller than an inner diameter of the duct on its upstream side.

5. The propeller setting the small duct according to any one of claims 1 to 4, wherein a center of the duct matches with an axis of the propeller.
6. The propeller setting the small duct according to any one of claims 1 to 5, wherein the duct is mounted on a stern tube of the ship's hull or a ship's hull end which covers the stern tube through a strut.
7. The propeller setting the small duct according to any one of claims 1 to 6, wherein an inner surface of the duct has a fixed blade which forms a flow toward the propeller as a counterflow.
8. The propeller setting the small duct according to claims 6 and 7, wherein the strut also functions as the fixed blade, and the strut is twisted in a direction opposite from a rotation direction of the propeller.
9. A ship comprising the propeller setting the small duct according to any one of claims 1 to 8.

Patentansprüche

1. Propellereinstellung mit kleinem Kanal, umfassend einen am Heck eines Schiffsrumpfes montierten Propeller (10) und einen vor dem Propeller (10) angeordneten Kanal (20),

dadurch gekennzeichnet, dass

ein Durchmesser des Kanals (20) auf 20% oder mehr und 50% oder weniger eines Durchmessers (D_p) des Propellers (10) eingestellt ist, und eine Steigung (H) des Propellers (10) eine abnehmende Steigung ist, die in radialer Richtung des Propellers (10) abnimmt, und die an einem Schaufelfuß des Propellers einen Höchstwert erreicht, und an der Schaufelspitze des Propellers einen Mindestwert erreicht, und ein Abstand (L) zwischen dem hinteren Ende des Kanals (20) und einer Vorderkante des Propellers (10) auf 0,5% oder mehr und 15% oder weniger des Durchmessers (D_p) des Propellers (10), von dem eine Interferenz spürbar wird, eingestellt ist.

2. Propellereinstellung mit kleinem Kanal nach Anspruch 1, wobei der Höchstwert der Steigung auf 120% oder mehr und 160% oder weniger des Mindestwertes der Steigung eingestellt ist.
3. Propellereinstellung mit kleinem Kanal nach Anspruch 1 oder 2,

wobei eine Querschnittsform des Kanals als konvexe Form, die nach innen zunimmt, ausgebildet ist, ein vorstehendes Ausmaß der konvexen Form auf einer vorgelagerten Seite des Kanals größer ist, und ein Wölbungsverhältnis auf 6% oder mehr und 16% oder weniger eingestellt ist.

4. Propellereinstellung mit kleinem Kanal nach einem der Ansprüche 1 bis 3, wobei der Kanal ein Beschleunigungskanal ist, bei dem ein Innendurchmesser des Kanals an seiner nachgelagerten Seite kleiner ist als ein Innendurchmesser des Kanals an seiner vorgelagerten Seite.
5. Propellereinstellung mit kleinem Kanal nach einem der Ansprüche 1 bis 4, wobei die Mitte des Kanals mit der Achse des Propellers übereinstimmt.
6. Propellereinstellung mit kleinem Kanal nach einem der Ansprüche 1 bis 5, wobei der Kanal an einem Stevenrohr des Schiffsrumpfes oder am Ende des Schiffsrumpfes, das das Stevenrohr über eine Strebe abdeckt, montiert ist.
7. Propellereinstellung mit kleinem Kanal nach einem der Ansprüche 1 bis 6, wobei eine Innenseite des Kanals eine feste Schaufel besitzt, die eine Strömung zu dem Propeller als Gegenströmung bildet.
8. Propellereinstellung mit kleinem Kanal nach Anspruch 6 und 7, wobei die Strebe auch als feste Schaufel fungiert und die Strebe in eine Richtung entgegen der Drehrichtung des Propellers verdreht ist.
9. Schiff, umfassend die Propellereinstellung mit kleinem Kanal nach einem der Ansprüche 1 bis 8.

Revendications

1. Petit carénage de réglage d'hélice incluant une hélice (10) montée sur une poupe d'une coque de bateau et un carénage (20) agencé devant l'hélice (10), **caractérisé en ce que** un diamètre du carénage (20) est fixé à 20 % ou plus et 50 % ou moins d'un diamètre (D_p) de l'hélice (10), et un pas (H) de l'hélice (10) est un pas décroissant qui diminue dans une direction radiale de l'hélice (10), et qui atteint une valeur maximale au niveau d'une emplanture de pale de l'hélice et atteint une valeur minimale au niveau de l'extrémité de pale de l'hélice, et une distance (L) entre une extrémité arrière du carénage (20) et un bord avant de l'hélice (10) est fixée à 0,5 % ou plus et 15 % ou moins du diamètre

(Dp) de l'hélice (10) dont l'interférence devient remarquable.

2. Petit carénage de réglage d'hélice selon la revendication 1, dans lequel la valeur maximale du pas est fixée à 120 % ou plus et 160 % ou moins de la valeur minimale du pas. 5
3. Petit carénage de réglage d'hélice selon la revendication 1 ou 2, dans lequel une forme de section transversale du carénage est formée comme une forme convexe qui augmente vers l'intérieur, un degré de projection de la forme convexe est supérieur sur un côté amont du carénage, et un rapport de cambrure est fixé à 6 % ou plus et 16 % ou moins. 10
15
4. Petit carénage de réglage d'hélice selon l'une quelconque des revendications 1 à 3, dans lequel le carénage est un carénage de type à accélération dans lequel un diamètre intérieur du carénage sur son côté aval est plus petit qu'un diamètre intérieur du carénage sur son côté amont. 20
25
5. Petit carénage de réglage d'hélice selon l'une quelconque des revendications 1 à 4, dans lequel un centre du carénage correspond à un axe de l'hélice. 30
6. Petit carénage de réglage d'hélice selon l'une quelconque des revendications 1 à 5, dans lequel le carénage est monté sur un tube d'étambot de la coque du navire ou d'une extrémité de coque du navire qui recouvre le tube d'étambot par l'intermédiaire d'une entretoise. 35
7. Petit carénage de réglage d'hélice selon l'une quelconque des revendications 1 à 6, dans lequel une surface intérieure du carénage a une pale fixe qui forme un écoulement vers l'hélice comme un contre-courant. 40
8. Petit carénage de réglage d'hélice selon les revendications 6 et 7, dans lequel l'entretoise sert également de pale fixe, et l'entretoise est déformée dans un sens opposé à un sens de rotation de l'hélice. 45
9. Navire comportant le petit carénage de réglage d'hélice selon l'une quelconque des revendications 1 à 8. 50

55

[Fig. 1]

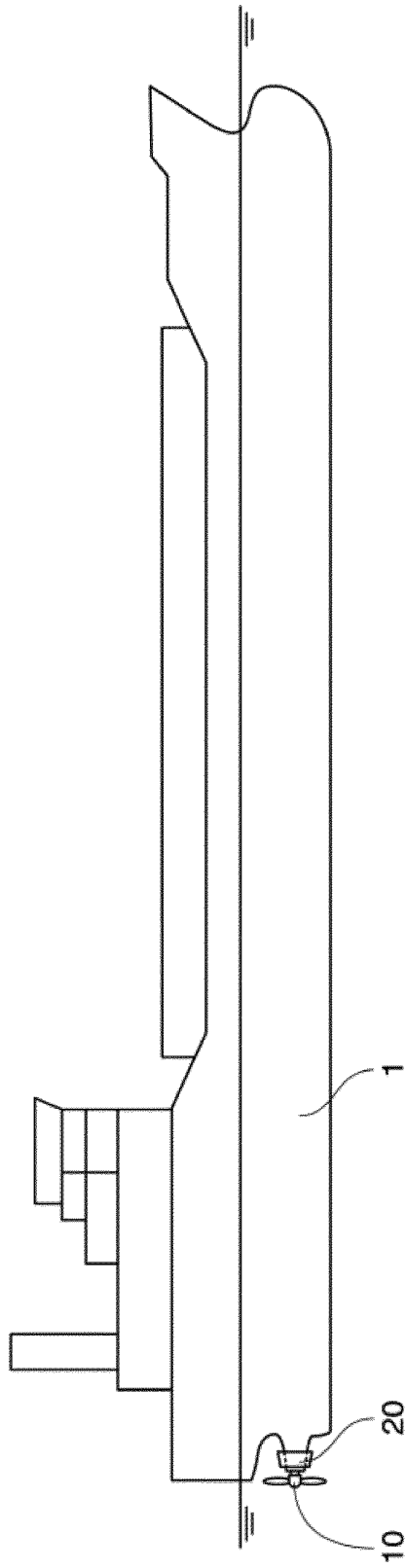

[Fig. 2]

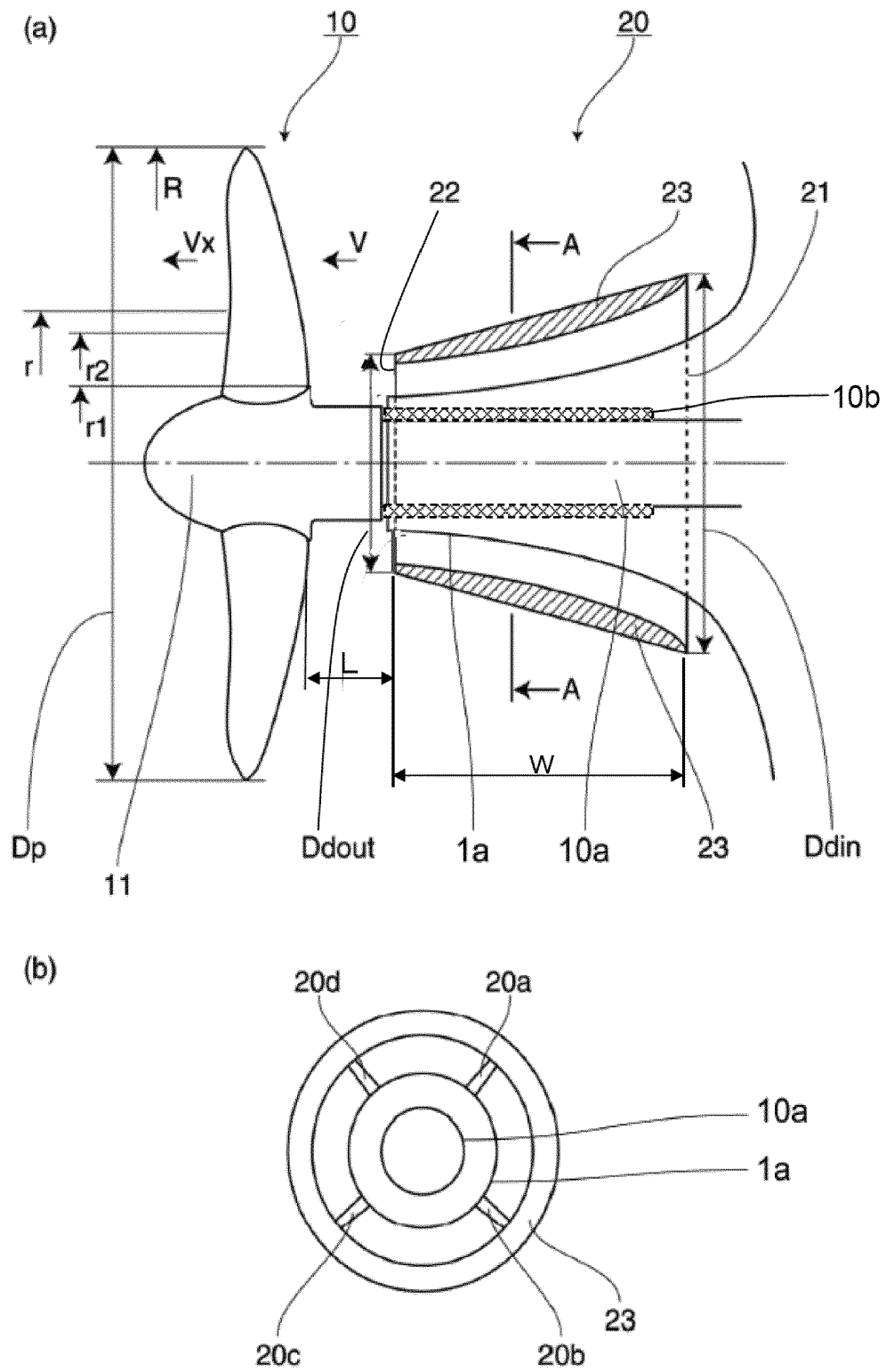

[Fig. 3]

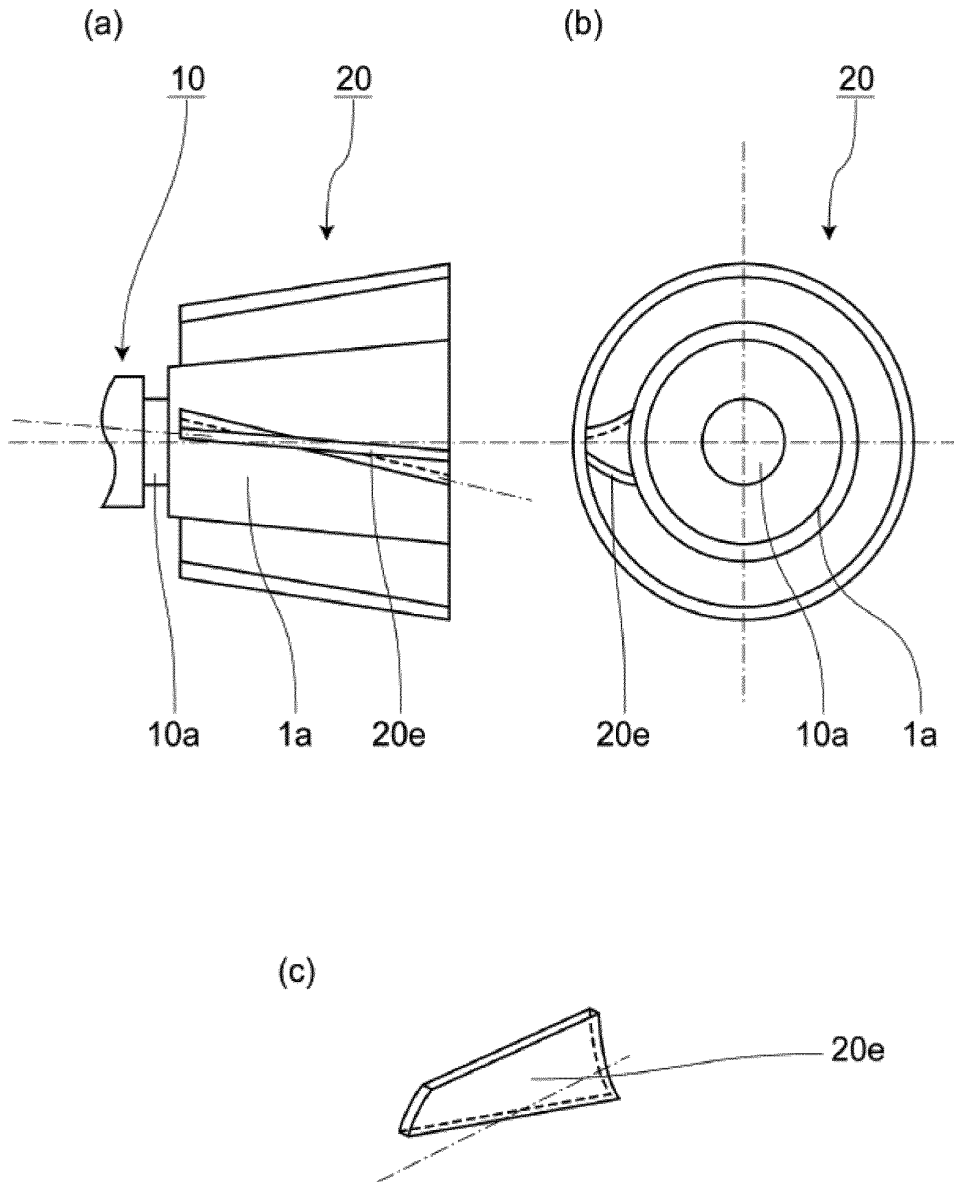

[Fig. 4]

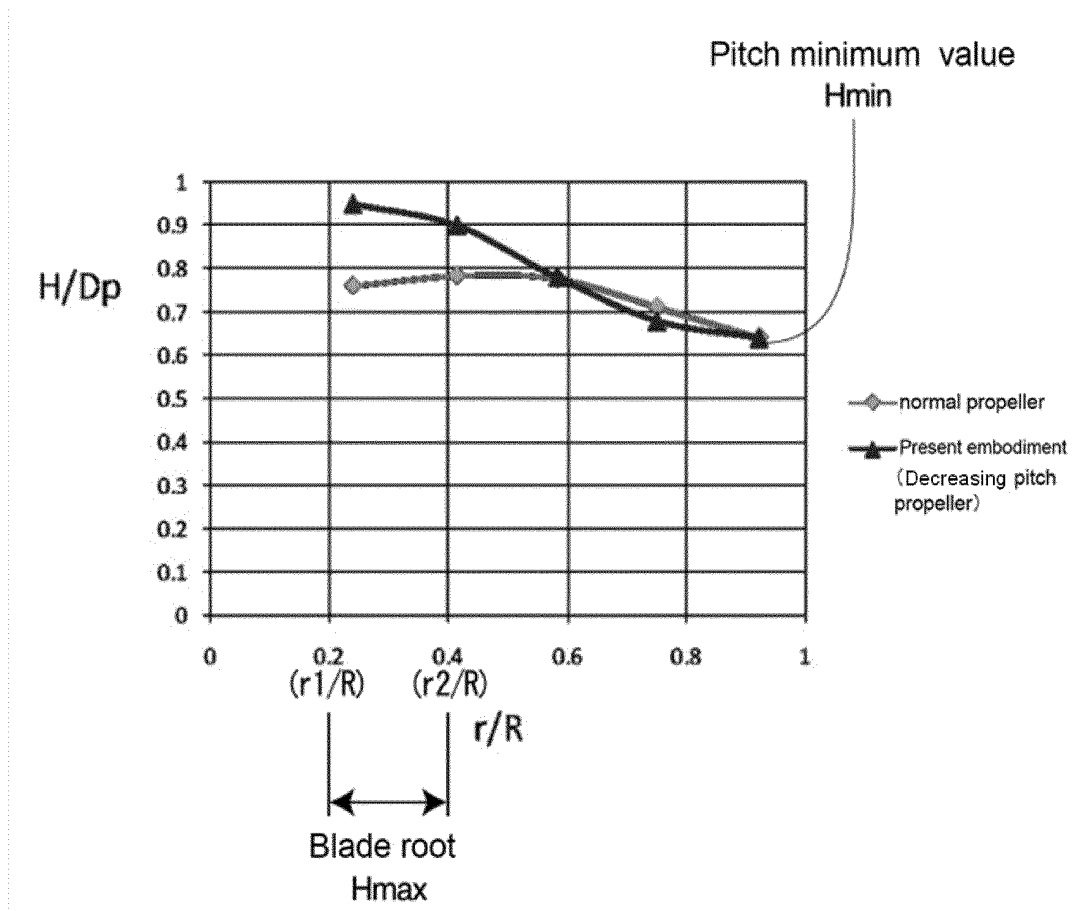

[Fig. 5]

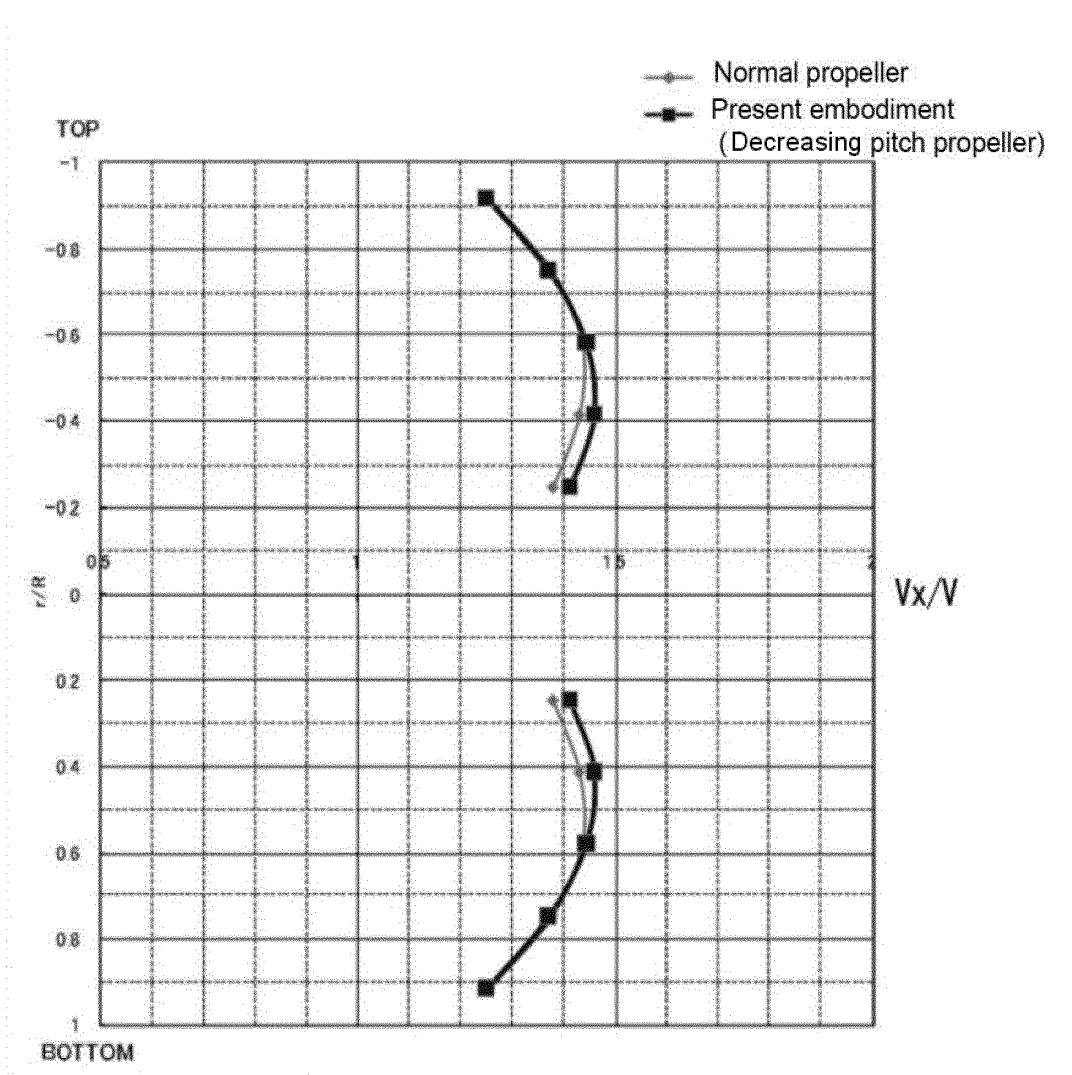

[Fig. 6]

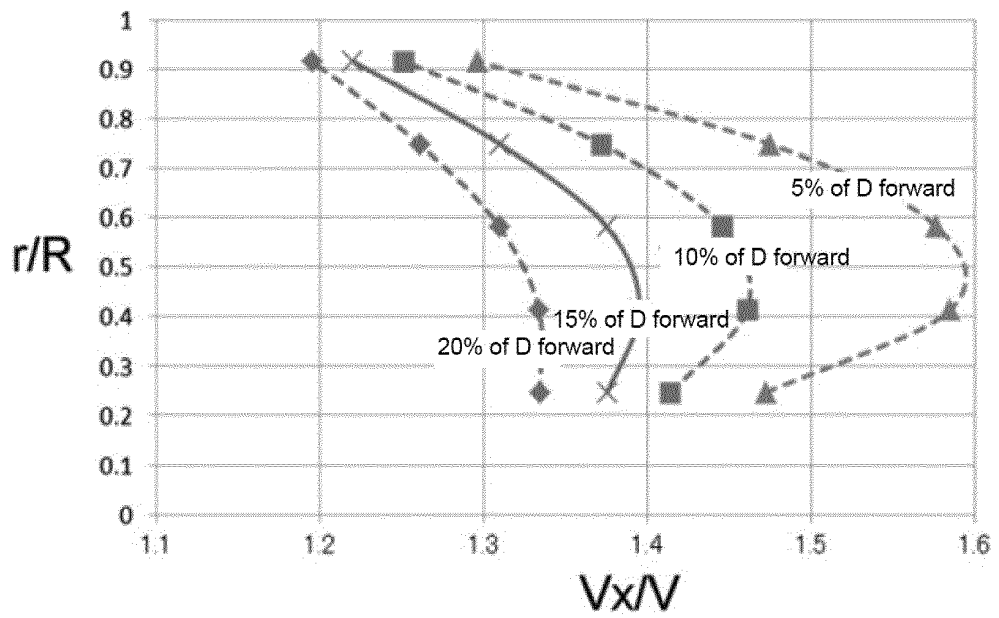

[Fig. 7]

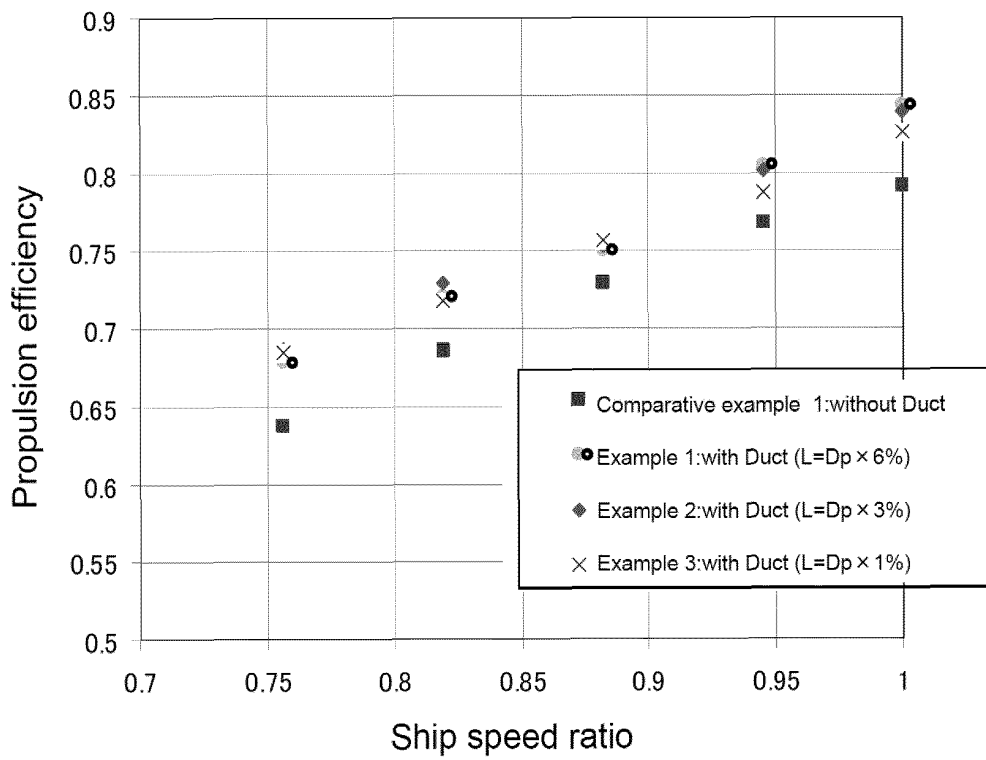

[Fig. 8]

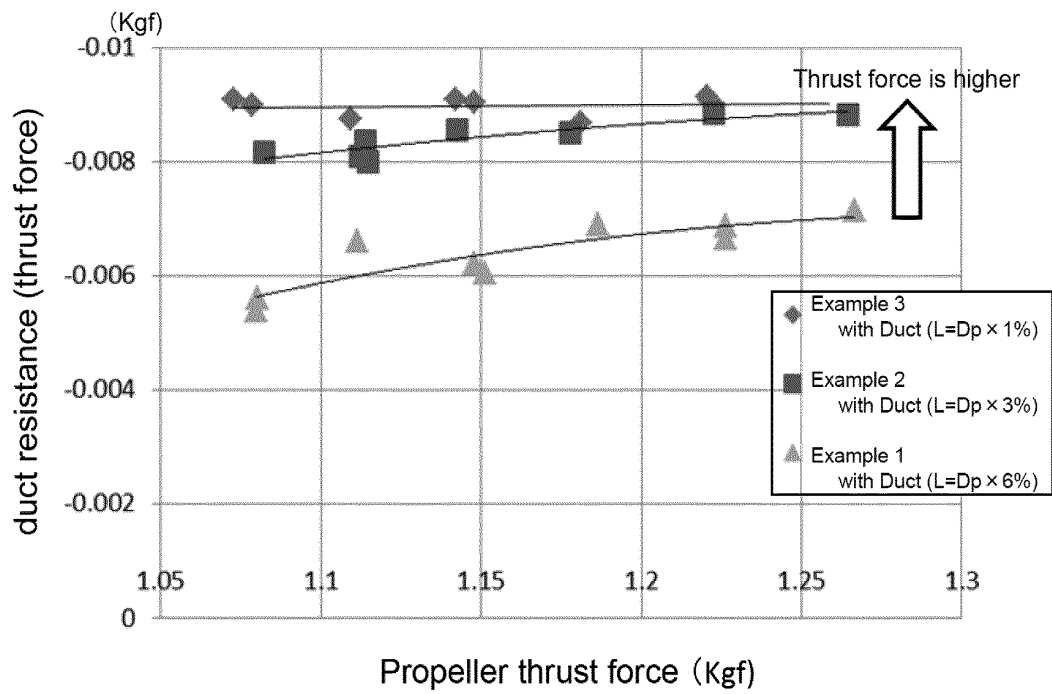

REFERENCES CITED IN THE DESCRIPTION

This list of references cited by the applicant is for the reader's convenience only. It does not form part of the European patent document. Even though great care has been taken in compiling the references, errors or omissions cannot be excluded and the EPO disclaims all liability in this regard.

Patent documents cited in the description

- US 5752865 A [0007]
- JP H9175488 B [0013]
- JP S5632396 B [0013]
- JP H220180 B [0013]
- JP H317996 B [0013]
- JP 2008143488 A [0013]
- JP 2007331549 A [0013]
- JP 2002220089 A [0013]
- JP H10264890 B [0013]